



# MTH

## Energy meter with multi-jet flow meter

Multi-jet energy meters for horizontal or vertical pipe mounting.

MTH is a range of combined energy meters intended for heating or cooling and consists of a multi-jet flow meter for horizontal or vertical mounting, a pair of temperature sensors and a calculator.

### Function

The menu system, available in the display, makes it possible to read a large number of parameters, such as heat and cold consumption, total energy spent on heating and cooling, temperatures along with current energy consumption.

Installation is normally in the return pipe.

MTH comes equipped with two PT500 temperature sensors. The resistors for the sensors are composed of platinum and maintain a standard of DIN IEC 60751.

### Mounting

The MTH models are available with both flanged and threaded connections. The flanged version is designed for horizontal mounting, and the threaded version is available for both horizontal, vertical rising pipe or vertical falling pipe mounting. See selection table on page 2.

The calculator is can be wall mounted or DIN rail mounted.

### Nominal flow sizes and pulse values

Multi-jet flow meters with watertight cast reed contacts in the MTH series can be ordered in nominal flow sizes from 1.5 up to 10 m<sup>3</sup>/h. Meters in the MTH range have a pulse value of 10 l/imp.

### Short facts about MTH

- Multi-jet flow meters for nominal flows from 1.5 up to 10 m<sup>3</sup>/h
- EEPROM prevents data loss
- For horizontal or vertical pipe mounting
- Reed contact measurement with carbide-sapphire bearing
- Available with M-Bus, pulse output or M-Bus and 2 pulse inputs

### High reliability

The calculator features a high accuracy of measurement, in addition to a long life and robust design. The calculator utilizes EEPROM memory, meaning loss of data does not occur if the battery is changed.

### Flexible design

Due to the multiple combination options offered by its components, meters in the MTH range can easily be adapted to suit a large number of individual requirements. Models with M-Bus, pulse output or M-Bus + pulse input are available.

Energy meters with M-Bus have a default adress of "0", which is not a valid primary communication address. This primary address can be changed by searching for secondary addresses (i.e., the ID number of the meter). For more information on different options, see ordering examples and item number structure overleaf.

**Ordering code selection table**

Options	MTH-						
Connection and installation position (length of meter)	Flanged horizontal (DN20=190 mm, DN25=260 mm, DN40=300 mm)	FH					
	Threaded horizontal (DN20=190 mm, DN25=260 mm, DN40=300 mm)	TH					
	Threaded vertical rising pipe (DN20=105 mm, DN25=150 mm, DN40=200 mm)	TVR					
	Threaded vertical falling pipe (DN20=105 mm, DN25=150 mm, DN40=200 mm)	TVF					
Flow select m <sup>3</sup> /h (DN) (connection)	1.5 m <sup>3</sup> /h (DN20) (Flanged PN16 or G1" thread on body)		20-1,5				
	2.5 m <sup>3</sup> /h (DN20) (Flanged PN16 or G1" thread on body)		20-2,5				
	3.5 m <sup>3</sup> /h (DN25) (Flanged PN16 or G1 1/4" thread on body)		25-3,5				
	6.0 m <sup>3</sup> /h (DN25) (Flanged PN16 or G1 1/4" thread on body)		25-6,0				
	10 m <sup>3</sup> /h (DN40) (Flanged PN16 or G2" thread on body)		40-10				
Type of measurement and installation point	Heating, installation of flow meter in return pipe (MID approval)			-	HR		
	Cooling <sup>1</sup> , installation of flow meter in return pipe			-	CR		
	Heating and cooling in combination <sup>2</sup> , installation of flow meter in return pipe.			-	HCR		
Communication interface	M-Bus					-	M
	M-Bus with 2 pulse inputs					-	MPI
	Pulse output for energy					-	PO

<sup>1</sup> National German approval.

<sup>2</sup> MID approval for heating, not for cooling.

If any further requirements or options are needed, please contact Regin.

**Ordering code table explanation****Example 1:**

Desired application: Meter with 1.5 m<sup>3</sup>/h. Heating, vertical installation in return falling pipe. M-Bus.

Resulting item ordering number: MTH-TVF20-1,5-HR-M

**Possible accessories needed:**

- Sensor pockets (2pcs): TH-85-½
- Brass threaded fittings (2pcs): VSR-¾, alt. ball valve (2pcs): KH-1

**Example 2:**

Desired application: Meter with 6.0 m<sup>3</sup>/h, DN25. Cooling, horizontal installation in return pipe, flanged, M-Bus + pulse input.

Resulting item ordering number: MTH-FH-25-6,0-CR-MPI

**Possible accessories needed:**

- Sensor pockets (2pcs): TH-85-½

## Accessories

Brass threaded fittings with coupling ring and gasket

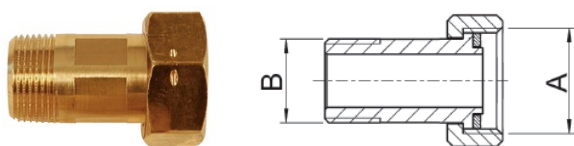

Meter DN	Connection A	Connection B	Compatible with	Article number
20	G1	R $\frac{3}{4}$	$q_p$ 1.5/2.5 m <sup>3</sup> /h	VSR- $\frac{3}{4}$
25	G1 $\frac{1}{4}$	R1	$q_p$ 3.5/6 m <sup>3</sup> /h	VSR-1
40	G2	R $\frac{1}{2}$	$q_p$ 10 m <sup>3</sup> /h	VSR-1 $\frac{1}{2}$

Ball valves with coupling ring and gasket

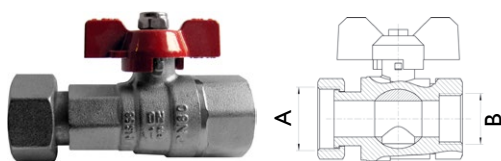

Meter DN	Connection A	Connection B	Compatible with	Article number
20	G1	Rp1	$q_p$ 0.6/1.5/2.5 m <sup>3</sup> /h	KH-1
25	G1 $\frac{1}{4}$	Rp1 $\frac{1}{4}$	$q_p$ 3.5/6 m <sup>3</sup> /h	KH-1 $\frac{1}{4}$
40	G2	Rp2	$q_p$ 10 m <sup>3</sup> /h	KH-2

Temperature pockets for installation of universal temperature sensor with 6 mm sheath diameter

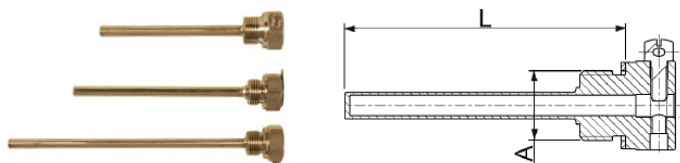

Connection A	Installation length L	Compatible with	Article number
G $\frac{1}{2}$	85 mm	$q_p$ 1.5 m <sup>3</sup> /h - 10 m <sup>3</sup> /h	TH-85- $\frac{1}{2}$

Threaded adapters to replace flow meter temporarily or permanently



Meter DN	Connection A	Installation length L	Compatible with	Article number
20	G1	105 mm	$q_p$ 1.5/2.5 m <sup>3</sup> /h	PS-105-1
20	G1	190 mm	$q_p$ 1.5/2.5 m <sup>3</sup> /h	PS-190-1
25	G1 $\frac{1}{4}$	150 mm	$q_p$ 3.5/6 m <sup>3</sup> /h	PS-150-1 $\frac{1}{4}$
25	G1 $\frac{1}{4}$	260 mm	$q_p$ 3.5/6 m <sup>3</sup> /h	PS-260-1 $\frac{1}{4}$
40	G2	200 mm	$q_p$ 10 m <sup>3</sup> /h	PS-200-2
40	G2	300 mm	$q_p$ 10 m <sup>3</sup> /h	PS-300-2

### Installation example, heating

### Installation example, cooling

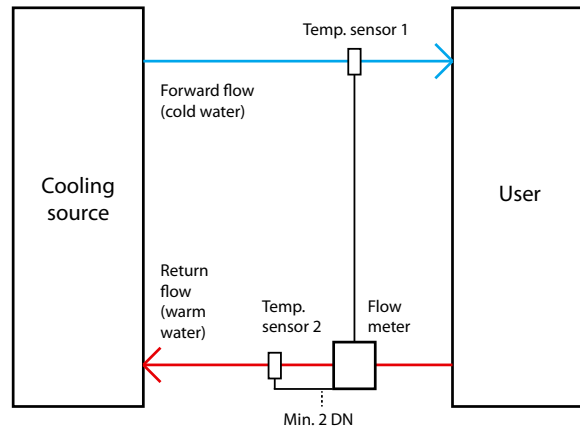
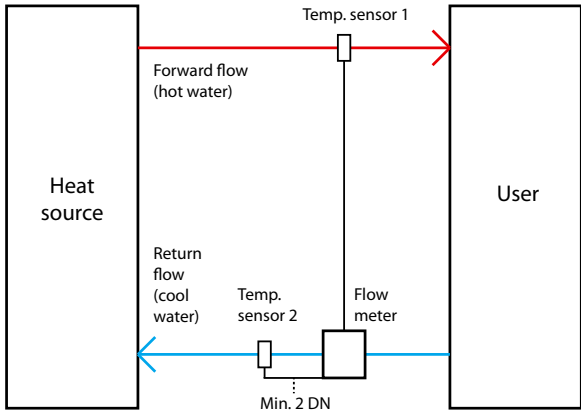

### Pressure drop curves

Pressure drop curve of the multi-jet flow meters, horizontally mounted

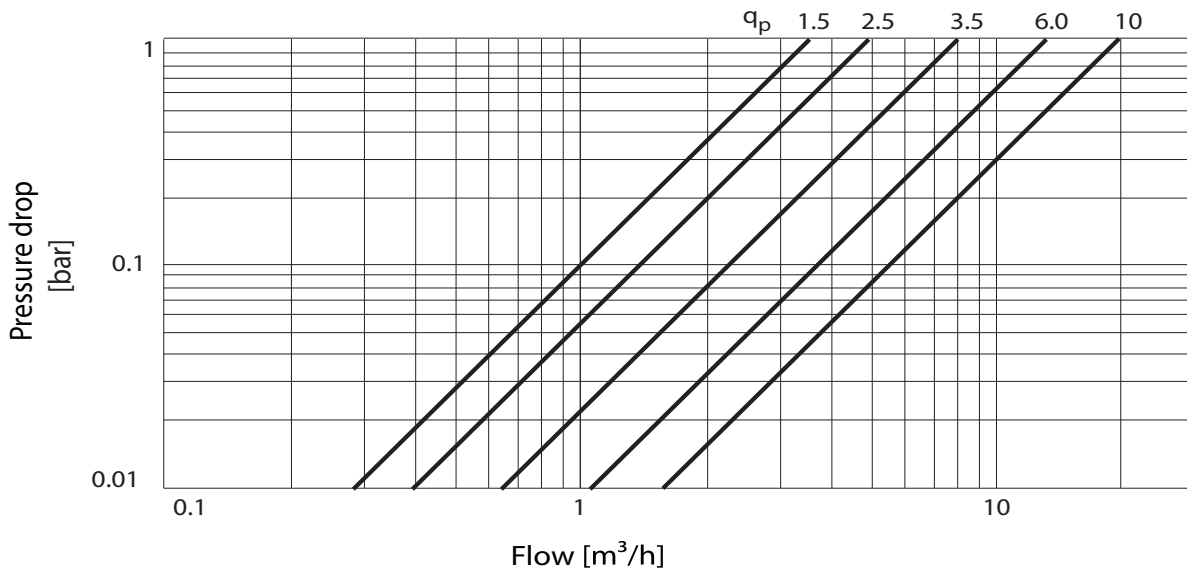

Pressure drop curve of the multi-jet flow meters, vertically mounted

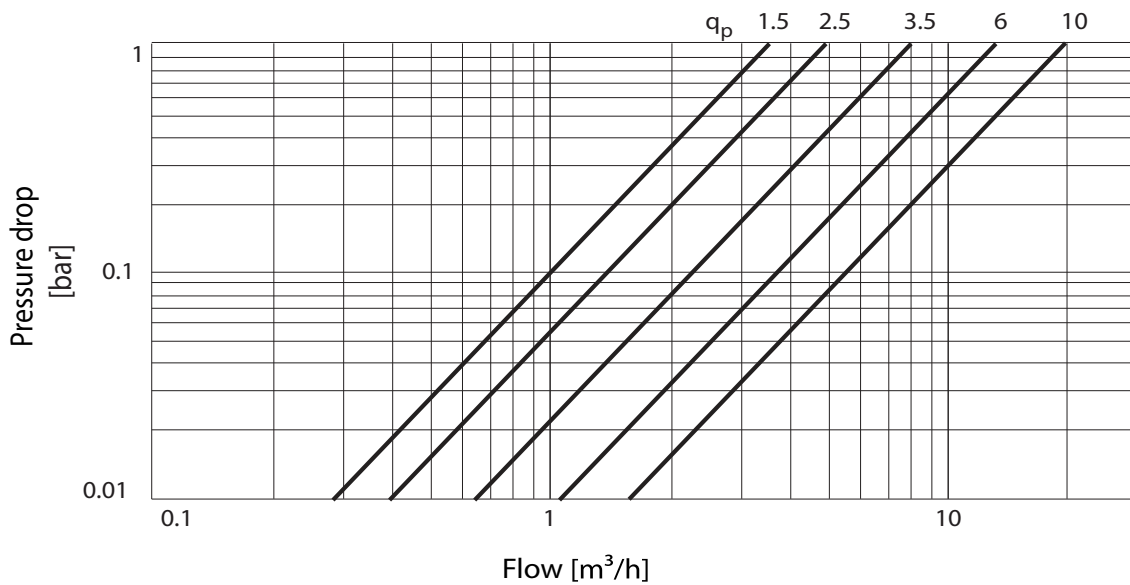

## Technical data, calculator

Power supply	3V lithium AA battery, replaceable
Temperature range	1...150°C
Temperature difference	
cooling	3...100 K
heating	3...100 K
Temperature resolution	0.01°C
Measurement frequency	Every 30 s
Ambient temperature	5...55°C
Storage temperature	5...55°C
Protection class	IP65
Memory	EEPROM, data stored daily
Billing dates	24 monthly values (15 in display), annual billing date selectable
Interfaces	M-Bus, pulse output or M-Bus with 2 pulse inputs
<b>CE</b>	<p><b>Measuring Instruments Directive:</b> This product conforms to the requirements of the Measuring Instruments Directive 2004/22/EC through product standards OIML R75, EN 1434, EN 60751, EN 14154 and PTB-Richtlinie K 7.1.</p> <p><b>Low Voltage Directive (LVD) standards:</b> This product conforms to the requirements of the European Low Voltage Directive (LVD) 2006/95/EC through product standards EN 61140, VDE 0140-1, EN 60529 and DIN 40050.</p> <p><b>EMC emissions &amp; immunity standards:</b> This product conforms to the requirements of the EMC Directive 2004/108/EC through product standards EN 13757-2, EN 13757-3 and DIN 12900-1.</p> <p><b>RoHS:</b> This product conforms to the Directive 2011/65/EU of the European Parliament and of the Council.</p>

## Technical data, temperature sensors

Platinum precision resistors	PT500; separately approved type as per EN60751, unshielded
Sensor diameter	Ø 6.0 mm
Sensor cable length	3 m (2-wire technique)
Installation	Indirect in temperature pocket or direct (up to 50 mm) as per EN1434

## Technical data, flow meter

Nominal flow $q_p$	1.5...10 m <sup>3</sup> /h
Nominal diameter DN	20...40 mm
Pressure rating	PN16
Maximum flow $q_s$	3...20 m <sup>3</sup> /h
Lower measuring range limit $q_i$	0.0030...0.160 m <sup>3</sup> /h
Flow at 0.1 bar pressure drop	1.0...6.3 m <sup>3</sup> /h
Media	Water (only permissible media)
Maximum temperature range	0...120°C
Pulse value	10 l/Imp
Cable length (to calculator)	3 m
Dial indication range for volume	
Min.	0.05 l
Max.	100.000 m <sup>3</sup>

Dimensions, horizontally mounted, threaded

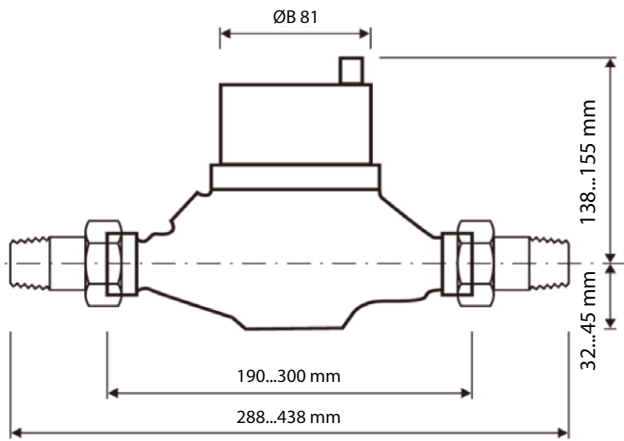

Dimensions, calculator

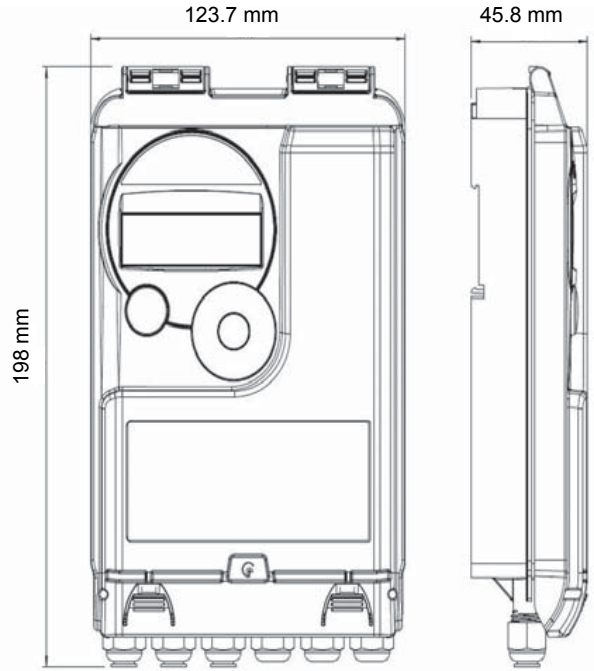

Dimensions, horizontally mounted, flanged

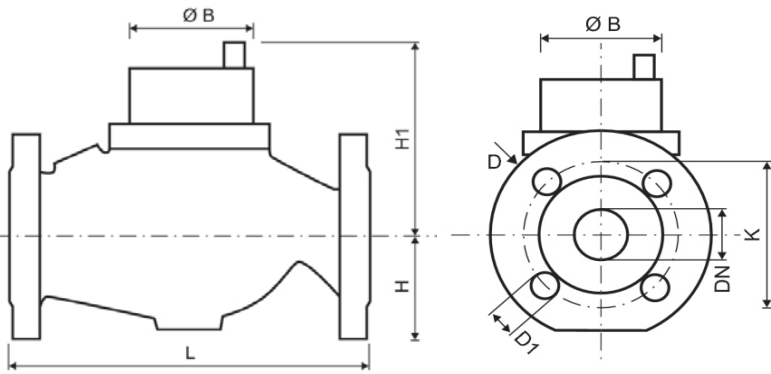

Dimensions, flanged (mm)					
DN	20	20	25	25	40
Diameter ØD	105	105	115	115	150
Bolt hole diameter ØD	75	75	85	85	110
No. of screws	4	4	4	4	4
Screw hole diameter D1	14	14	14	14	18
Height H1	138	138	140	140	155
Height H	50	50	50	52	70

Dimensions, vertically mounted

