



SDD-S65(-RAC) and SDD-OE65(-RAC)

Single tube smoke detector for duct mounting

The SDD-range of smoke detectors are duct mounted and for use in ventilation systems. They are constructed to meet the high demands of a modern fire installation.

- ✓ Optical or ionisation models available
- ✓ Multiple detectors can be connected to a single control unit (does not apply to SDD-S65-RAC or SDD-OES65-RAC)
- ✓ Service alarm signal available
- ✓ The detector is bayonet mounted to simplify service and maintenance
- ✓ Compact design
- ✓ RFI-protected (radio interferences)

Function

The detector comes in two different types: one optical (SDD-OE...) and one ionisation (SDD-S65...). Both types are available with or without relay.

They are intended for use together with Regin's ABV... series of control units.

The RAC models have a relay and are not to be connected to Regin's control units ABV... The built-in relay makes it possible for the unit to independently give an alarm without connection to a control unit.

A 540 mm aluminium venturi tube is delivered with the detector. The tube can be shortened to fit more duct sizes. A longer venturi tube is also available to order from Regin.

The detector housing has a window giving a clear view of the flow indicator and the alarm LED.

The detectors are approved according to EN54 and have been tested and approved by SBSC.

The detectors have a built-in service alarm function for sensing the dust and dirt accumulation which inevitably occurs over time. When the degree of dirt has reached the level at which there is the risk of false alarms, a service alarm is given indicating that cleaning is required.

The detectors should be tested and cleaned yearly to ensure proper function. The function of the detectors can be tested by using test smoke (available to order from Regin). The cover can be cleaned with a vacuum cleaner.

SDD-OES65...

The optical detector reacts to visible smoke particles (residues from combustion).

It works according to the reflection principle and consists of a measuring chamber that has air-inlets via a labyrinth which keeps out ambient light.

An infrared LED and a photo transistor are placed in the measuring chamber. They are located so the light from the LED doesn't shine on the light sensitive transistor.

If smoke particles enter the measuring chamber some of the light from the LED will be reflected by the particles and hit the photo transistor which activates the alarm.

SDD-65...

The ionisation detector reacts to both visible and invisible smoke particles and can therefore detect fire at an early stage.

It uses the two-chamber principle, which means that the detector has an outer and a, more shielded, inner chamber. Since smoke reaches the outer chamber first, there will be imbalance and an alarm will be triggered.

Features

Alarm indication

The detector has a red LED, clearly visible through the window on the housing. The LED is normally off and lights up when there is a fire alarm.

Service alarm signal

A red LED lights up on the detector and a yellow LED on the connected control unit ABV... when the detector is so contaminated that the service alarm is triggered. The detector must then be cleaned. The service alarm is reset when the detector is cleaned and re-installed.

Flow indication

The detector has a built-in flow indicator with a red signal flag which is located on the air inlet. During normal operation, it will be lifted by the flow of air, indicating air flow through the detector.

Installation

The detector should be mounted at least three duct widths away from duct bends and fresh air inlets. The holder is designed so that it will also fit directly onto round ducts.

The detector is connected to the control unit with a two-wire loop. Multiple detectors can be connected to the same control unit. An end resistor should be connected to the last detector to end the loop.

The venturi tube is mounted in the ventilation duct through a Ø 30 mm hole. The venturi tube can be shortened for smaller ducts. For larger ventilation ducts, a longer venturi tube can be ordered.

When the detector has to be mounted at a distance from the duct (e.g. when insulation material is used) the mounting plate TDS should be used. A distance bushing for mounting on the venturi tube is delivered with TDS.

Technical data

Supply voltage	9...33 V DC (via ABV control unit)
Supply voltage, RAC models	24 V AC \pm 15 %
Relay	Max 24 V AC / 2A or 24 V DC / 1A (Resistive load)
Current consumption, normal	10 mA
Current consumption during alarm	50 mA
Current consumption during service alarm	20 mA
Temperature range	-20...+60 °C
Ambient humidity	Max. 95% RH
Wind speed	Up to 20 m/s
Mounting	Duct
Protection class	IP54
Smoke alarm	Red LED
Service alarm	Red LED on detector. Yellow LED on control unit.

Models

Article	Description	Radioactivity
SDD-OE65	Optical detector for loop mounting with control unit	-
SDD-OE65-RAC	Optical detector with relay output	-
SDD-S65	Ionisation detector for loop mounting with control unit	Americium 241; 0.9 μ Ci; 33.3 kBq
SDD-S65-RAC	Ionisation detector with relay output	Americium 241; 0.9 μ Ci; 33.3 kBq

CE

This product carries the CE mark. More information is available at www.regincontrols.com

Accessories

Article	Description
TDS	Mounting plate for insulated ducts
VR600	Venturi tube, 540 mm
VR2000	Venturi tube, 1940 mm

Dimensions

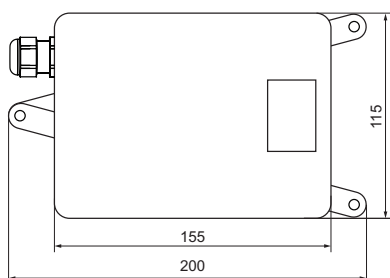

Measurements in mm unless otherwise specified.

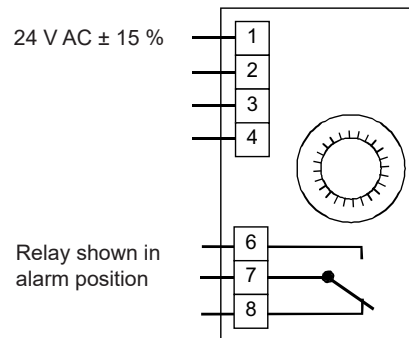
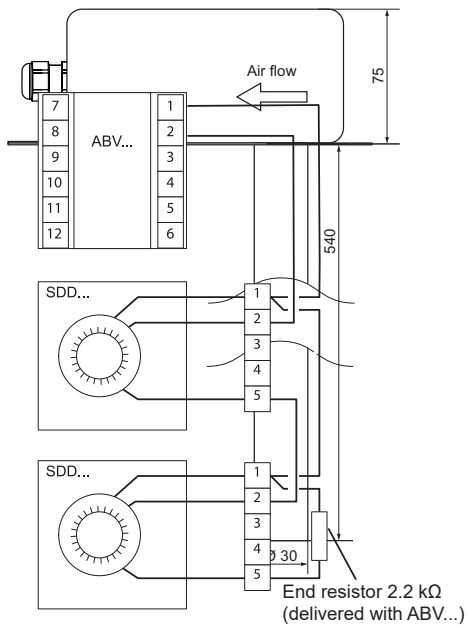

Wiring

Wiring SDD-S65-RAC and SDD-OE65-RAC

Product documentation

The product documentation can be downloaded from www.regincontrols.com

Wiring SDD-S65 and SDD-OE65 to ABV..

Note: -RAC models should not be mounted in a loop or to a control unit