



# Macurco™ CM-6, CM-12 Carbon Monoxide Detector, Controller and Transducer User Instructions



IMPORTANT: Keep these user instructions for reference.

# Table of Contents

- 1 General Safety Information..... 4
  - 1.1 General Description..... 4
  - 1.2 List of warnings and Cautions..... 4
- 2 Use Instructions and Limitations..... 5
  - 2.1 Use For ..... 5
  - 2.2 Do NOT use for ..... 5
  - 2.3 Features..... 6
  - 2.4 Specifications ..... 6
    - 2.4.1 6-Series Low Voltage..... 6
    - 2.4.2 12-Series Line Voltage..... 6
- 3 Installation Instructions ..... 7
  - 3.1 Location ..... 7
  - 3.2 Installation..... 7
    - 3.2.1 6-Series Low Voltage..... 7
    - 3.2.2 12-Series Line Voltage..... 12
  - 3.3 Terminal Connection ..... 17
    - 3.3.1 6-Series Low Voltage..... 17
    - 3.3.2 12-Series Line Voltage..... 17
- 4 Operations ..... 18
  - 4.1 Power up ..... 18
  - 4.2 Display turned “On” ..... 18
  - 4.3 Display turned “Off” ..... 19
  - 4.4 4-20 mA Loop ..... 19
  - 4.5 Default – Factory Settings ..... 20
    - 4.5.1 Selecting Default Configuration – “dEF” ..... 20
    - 4.5.2 Power-Up Test Setting – “PUt” ..... 21
    - 4.5.3 Display Setting – “dSP” ..... 21
    - 4.5.4 Buzzer Setting – “bUZ” ..... 21
    - 4.5.5 Alarm Relay Setting – “ArS” ..... 21
    - 4.5.6 Alarm Relay Configuration – “Arc”..... 21
    - 4.5.7 Fan Relay Setting – “FrS” ..... 21
    - 4.5.8 Fan Relay Delay Setting – “Frd” ..... 21
    - 4.5.9 Fan Relay Minimum Runtime Setting – “Frr” ..... 22
    - 4.5.10 Fan Relay Latching Setting – “FrL” ..... 22
    - 4.5.11 Trouble Fan Setting – “tFS” ..... 22
    - 4.5.12 4-20mA Output setting – “420”..... 22
    - 4.5.13 Calibration Period Settings – “CAL” ..... 22
- 5 Troubleshooting..... 23
  - 5.1 On-Board Diagnostics..... 23
    - 5.1.1 4-20mA troubleshooting..... 23
    - 5.1.2 “t” error codes ..... 23
  - 5.2 Sensor Poisons ..... 24
  - 5.3 End-of-Life Signal..... 24
- 6 Maintenance ..... 24
  - 6.1 Sensor Life Reset ..... 24
  - 6.2 Cleaning..... 25
- 7 Testing..... 25

- 7.1 Testing ..... 26
  - 7.1.1 Operation Test ..... 26
  - 7.1.2 Manual Operation Test ..... 26
- 7.2 Calibration and Test Kits..... 27
- 7.3 Gas Testing ..... 28
  - 7.3.1 Testing the Fan Relay ..... 28
  - 7.3.2 Testing the Alarm Relay ..... 28
  - 7.3.3 Testing the 4-20mA loop..... 29
  - 7.3.4 Aerosol Carbon Monoxide Test ..... 29
- 7.4 Field Calibration Procedure ..... 29
- 8 Appendix A – Table of Images ..... 31
- 9 Appendix B – Menu Structure ..... 32
  - 9.1 Main Menu ..... 32
  - 9.2 Auto Test Menu “bUZ” ..... 33
  - 9.3 Select Test Menu “tst” ..... 40
  - 9.4 Calibration Menu “CAL” ..... 41
  - 9.5 Sensor Reset Menu “SEn” ..... 42
- 11 Macurco Gas Detection Product limited warranty ..... 43
  - Technical Support Contact Information ..... Error! Bookmark not defined.**
  - General Contact Information ..... Error! Bookmark not defined.**

# 1 General Safety Information

The following instructions are intended to serve as a guideline for the use of the Macurco CM-6 and CM-12 Carbon Monoxide Detector. This manual will refer to these devices as CM-xx unless content is specific to a model. This manual is not to be considered all-inclusive, nor is it intended to replace the policy and procedures for your facility. If you have any doubts about the applicability of the equipment to your situation, consult an industrial hygienist or call Technical Support at 1-844-325-3050.

## 1.1 General Description

The Macurco CM-xx is a dual relay Carbon Monoxide (CO) detector, controller, and transducer. Available in both a low voltage (CM-6) and line voltage (CM-12) option. The CM-xx has selectable 4-20 mA output, buzzer and digital display options. It is an electronic detection system used to measure the concentration of Carbon Monoxide and provide feedback and automatic exhaust fan control to help reduce CO concentrations in parking garages, maintenance facilities or other commercial applications. The CM-xx is a low-level meter capable of displaying in the range 0-200 ppm (parts per million) of Carbon monoxide. The CM-xx is factory calibrated and 100% tested for proper operation but can also be calibrated in the field.

## 1.2 List of warnings and Cautions

 <b>WARNING</b>
Each person using this equipment must read and understand the information in this user manual before use. Use of this equipment by untrained or unqualified persons or use that is not in accordance with this user manual, may adversely affect product performance.
Use only for monitoring the gas which the sensor and monitor is designed to detect. Failure to do so may result in exposures to gases not detectable and cause serious injury or death. For proper use, see supervisor or user manual, or contact Technical Support at 1-844-325-3050.
This equipment may not function effectively below 0°F or above 125°F (-18°C or above 52°C). Using the detector outside of this temperature range may adversely affect product performance.
This detector helps monitor for the presence and concentration level of a certain specified airborne gas. Misuse may produce an inaccurate reading, which means that higher levels of the gas being monitored may be present and could result in overexposure and cause serious injury or death. For proper use, see supervisor or User manual, or contact Technical Support at 1-844-325-3050.
High voltage terminals (120/240 VAC) are located within this detector, presenting a hazard to service technicians. Only qualified technicians should open the detector case and service the internal circuits. Ensure power is de-energized from the detector relays prior to servicing the unit. Failure to do so may result in electrical shock.
Do not disassemble unit or attempt to repair or modify any component of this instrument. This instrument contains no user serviceable parts, and substitution of components may impair product performance.
Using a certified gas with a concentration other than the one listed for this detector when conducting a calibration or calibration verification test (bump test) will produce inaccurate readings. This means that higher levels of the gas being monitored may be present and could result in overexposure. For proper use, see supervisor or User manual, or contact Technical Support at 1-844-325-3050.

The following steps must be performed when conducting a calibration or calibration verification test (bump test) to ensure proper performance of the monitor. Failure to do so may adversely affect product performance.

- When performing a calibration or calibration verification test (bump test), only use certified calibration gas at the required concentration level.
- Do not test with expired calibration gas.
- Do not cover or obstruct display or visual alarm cover.
- Ensure sensor inlets are unobstructed and are free of debris

Failure to follow instructions outlined in this user manual can result in sickness or death.

## 2 Use Instructions and Limitations

### WARNING

Each person using this equipment must read and understand the information in this user manual before use. Use of this equipment by untrained or unqualified persons or use that is not in accordance with this user manual, may adversely affect product performance.

### 2.1 Use For

The CM-xx provides CO detection and automatic exhaust fan control for automotive maintenance facilities, enclosed parking garages, utility rooms, warehouses and other commercial applications. The CM-xx meets the requirements of the Uniform Building Code for enclosed garages and meets OSHA standards for CO exposure. CM-xx can be used stand alone, with the Macurco DVP-120 Detection and Ventilation Control Panel, other 12 VAC or 24 VDC fire/security panels or building automation systems.

### WARNING

Use only for monitoring the gas which the sensor and monitor is designed to detect. Failure to do so may result in exposures to gases not detectable and cause serious injury or death. For proper use, see supervisor or user manual, or contact Technical Support at 1-844-325-3050.

### 2.2 Do NOT use for

The CM-xx is not intended for use in hazardous locations or industrial applications such as refineries, chemical plants, etc. Do not mount the CM-xx where the normal ambient temperature is below 0°F or exceeds 125°F (-18°C or above 52°C). The CM-xx mounts on a type 4S electrical box supplied by the contractor. Do not install the CM-xx inside another box unless it has good air flow through it.

### WARNING

This equipment may not function effectively below 0°F or above 125°F (-18°C or above 52°C). Using the detector outside of this temperature range may adversely affect product performance.



## 2.3 Features

- ETL LISTED Certified to CSA C22.2 No 61010-1, Conforms to UL Std. 61010-1, UL Std. 2075<sup>1</sup>
- Low-level meter capable of displaying from 0-200 ppm of CO
- The CM-xx meets the Uniform Building Code for enclosed garages and meets OSHA standards for CO exposure
- Selectable fan and alarm relay activation
- 5 A SPDT fan relay controls starters of exhaust fans
- 0.5 A N.O. or N.C. alarm relay connects to warning devices or control panels
- 4-20 mA Current Loop
- CM-xx mounts on a standard 4x4 electrical box and becomes cover for the box
- Supervised system: any internal detector problem will cause the fan & Alarm relay to activate
- Calibration kit is available. One screw allows access for calibration or gas test

<sup>1</sup>Where required by federal, state, local regulations or the Authority Having Jurisdiction, CM-6 and CM-12 are required to be used with Listed Horn/Strobe model 78-2900-0211-X\* to meet the 85dB(A) Audibility requirements of Standards UL 2075.

\*Where "X" represents lens cover color, R for red lens cover, G for green lens cover, B for blue lens cover, O for amber lens cover, C for clear lens cover.

## 2.4 Specifications

- Shipping Weight: 1 pound (0.45 kg)
- Size: 4 1/2 x 4 x 2 1/8 in. (11.4 X 11.4 X 5.3 cm)
- Color: White or Dark gray
- Connections: plugs/terminals
- Mounting box: (not included) 4x4 electric
- Fan relay: 5 A, 240 VAC, pilot duty, SPDT, latching or non-latching
- Fan relay actuation: selectable at diS (disable), 15 ppm, 25 ppm, 35 ppm (default), 50 ppm or 100 ppm CO
- Fan Delay Settings of 0, 1, 3 (default), 5 and 10 minutes
- Fan Relay Minimum Runtime settings are 0 (default), 3, 5, 10 or 15 minutes
- Fan relay latching or not latching (default) selectable
- Alarm relay: 0.5A 120 V, 60 VA
- Alarm relay actuation: selectable N.O. (default) or N.C.
- Alarm relay settings: diS, 50 ppm, 100 ppm, 150 ppm and 200 ppm (default)
- Current Loop, 4-20 mA for 0-200 ppm CO, selectable to 'bAS' (default), 'EnH', OFF
- Calibration Period Settings: dis(default), 3, 6, 12 and 24 (months)
- Buzzer: 85 dBA at 10cm settable to off (default) or on
- Digital display: 3-digit LED selectable to off (default) or on.
- Operating Environment: 0°F to 125° F (-18°C to 52°C), 10 to 90% RH non-condensing

### 2.4.1 6-Series Low Voltage

- Power: 3 W (max) from 12 to 24 VAC or 12 to 32 VDC
- Current @ 24 VDC: 75 mA in alarm (two relays), 50 mA (fan relay only) and 23 mA standby

### 2.4.2 12-Series Line Voltage

- Power: 100-240VAC (50 TO 60 HZ)
- Current: 1.0 A MAX



### 3 Installation Instructions

#### WARNING

This detector helps monitor for the presence and concentration level of a certain specified airborne gas. Misuse may produce an inaccurate reading, which means that higher levels of the gas being monitored may be present and could result in overexposure and cause serious injury or death. For proper use, see supervisor or User manual, or contact Technical Support at 1-844-325-3050.

#### 3.1 Location

A CM-xx is normally mounted at breathing level, about 5 feet (1.5 meters) above the floor on a wall or column in a central area where air movement is generally good. The unit, on average, can cover approximately 5,000 sq. ft. (465 sq. meters) to 7,500 sq. ft. (697 sq. meters). The coverage depends on air movement within the room or facility. Extra detectors may be needed near any areas where people work or where the air is stagnant. Some of the factors that affect the coverage area are application type, personnel work areas and movement, room size, air movement, potential threat, mounting location, along with other site-specific factors that must be considered. Please check local regulations or requirements prior to installation. The CM-xx mounts on a 4x4 electrical box supplied by the contractor. Do not install the CM-xx inside another box unless it has good air flow through it. Do NOT mount the CM-xx where the normal ambient temperature is below 0°F or exceeds 125°F (below -18°C or above 52°C).

#### WARNING

High voltage terminals (120/240 VAC) are located within this detector (CM-12), presenting a hazard to service technicians. Only qualified technicians should open the detector case and service the internal circuits. Ensure power is de-energized from the detector relays prior to servicing the unit. Failure to do so may result in electrical shock.

#### 3.2 Installation

##### 3.2.1 6-Series Low Voltage

1. The CM-6 mounts on a 4" square (or 4x4) electrical box supplied by the contractor. Do not mount the CM-6 inside another box, unless it has good air flow through it.
2. Connect the CM-6 to Class 2 power supply only. It is suggested to use a separate transformer for powering the unit or units because of possible interferences from other devices on the same power supply.
3. Connect the CM-6 to the control cables with terminal plugs. When making connections, make sure the power is off.
4. There are two terminals for Power: 12 to 24 VAC or 12 to 32 VDC, with no polarity preference.
5. There are two terminals for the dry alarm relay contacts, again with no polarity preference. The alarm relay can switch up to 0.5 A 120 V, or 60 VA. The alarm relay is activated if gas reaches or exceeds the alarm settings. See section [4.5 Default – Factory Settings](#) of this User manual for details on relay settings.
6. The alarm relay can be configured to normally open (default) (N.O.) or normally closed (N.C.) and will activate if the gas concentration exceeds alarm set point. It will deactivate once the gas concentration drops below the alarm set point. Note that the “disable” setting will cause the alarm relay not to engage at all.
7. The dry contact, SPDT fan relay has three terminals. The common (COM.), normally open (N.O.) and the normally closed (N.C.) contact. The fan relay can switch up to 5.0 A up to 240 VAC. See section [4.5 Default – Factory Settings](#) of this User manual for details on relay settings.



8. The Fan Relay can be configured for latching or non-latching (default) when activated (when the gas concentration exceeds fan relay set point). Once latched in, power will need to be interrupted or the “TEST” button pressed to unlatch the relay condition.
9. The Fan Relay will engage if the fan setting Carbon Monoxide concentration is exceeded for longer than the Fan Relay Delay time. Unless it is configured for latching, the fan relay will disengage once both of these conditions have been met:
  - Carbon Monoxide concentration has dropped below fan setting
  - Fan Relay Run time has been exceededNote that the “disable” fan setting will cause the fan relay to not engage. The fan relay will engage in trouble fault condition (if the Trouble Fan Setting Option is set to “ON”) and will disengage once trouble fault condition is cleared.
10. The Current Loop is 4 mA in clean air and 4-20 mA for 0-200ppm CO

**NOTE:** 22 to 12 AWG wire shall be used. Wire used shall meet the temperature range of the detector i.e. 0°F to 125° F (-18°C to 52°C).

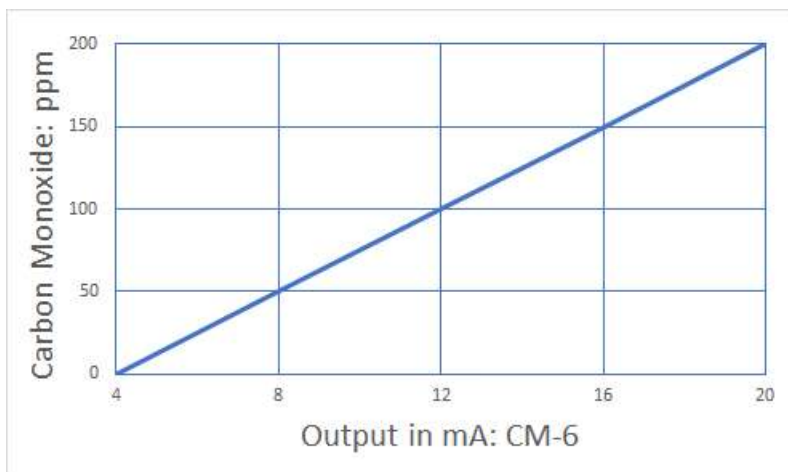

Figure 3-1 6-Series 4-20 mA Output diagram





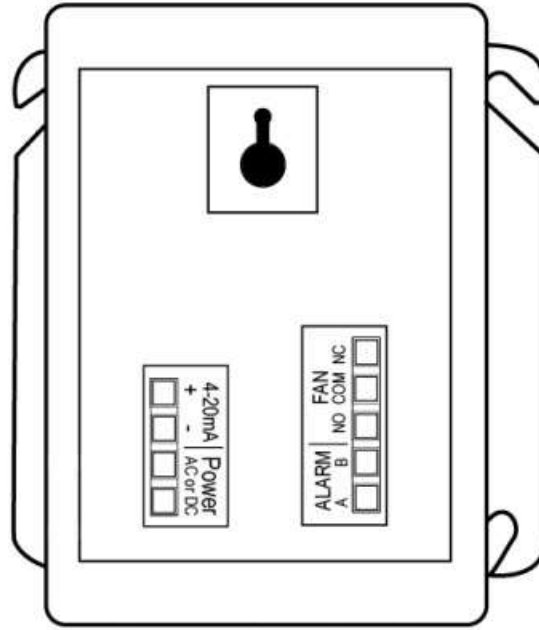

Figure 3-2 6-Series Rear View

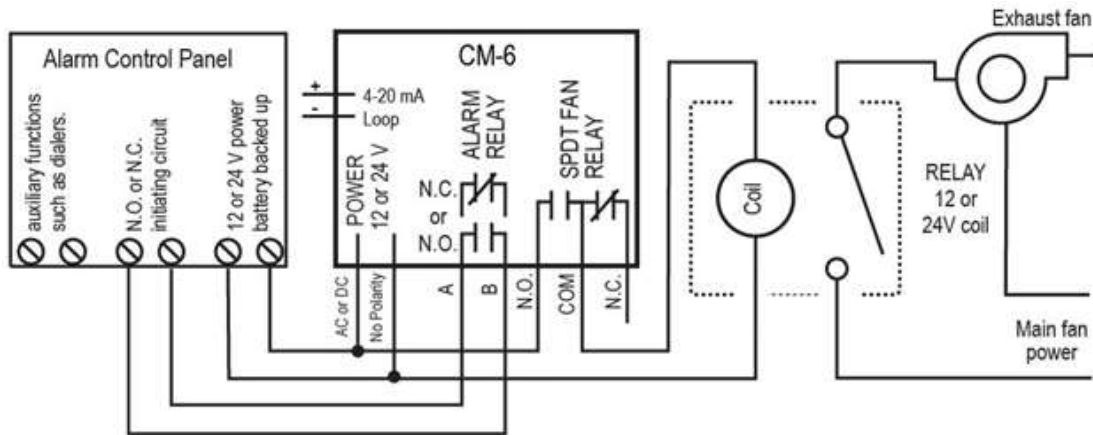

Figure 3-3 6-Series Alarm Control Panel diagram

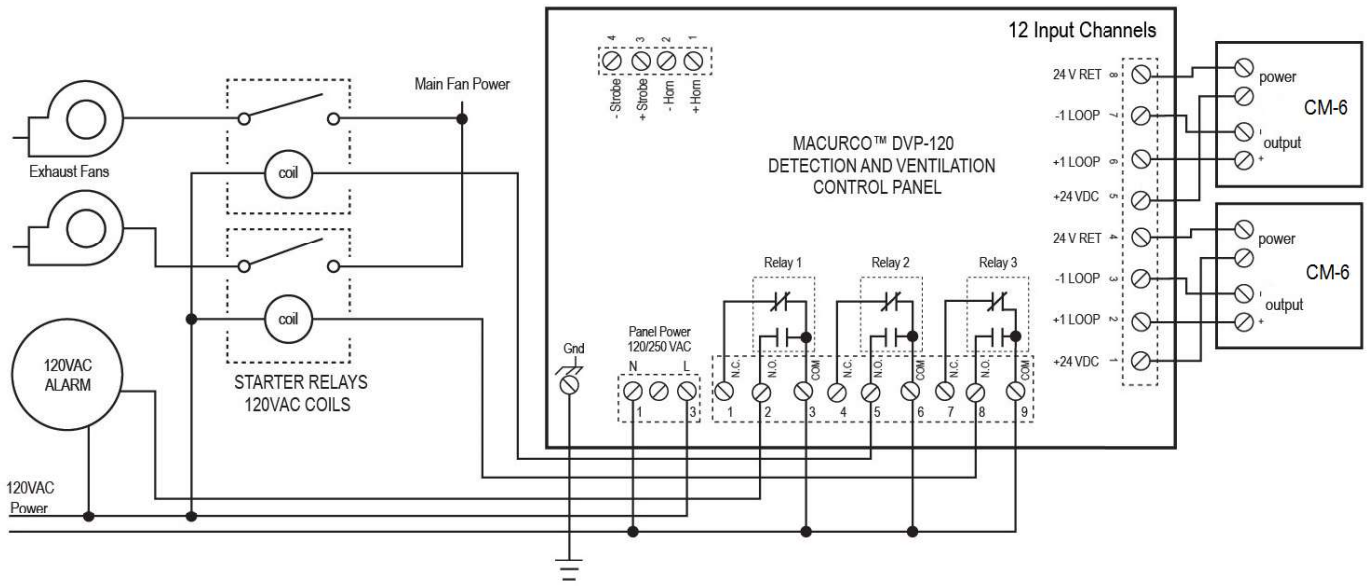

Figure 3-4 6-Series DVP-120 Control Panel diagram

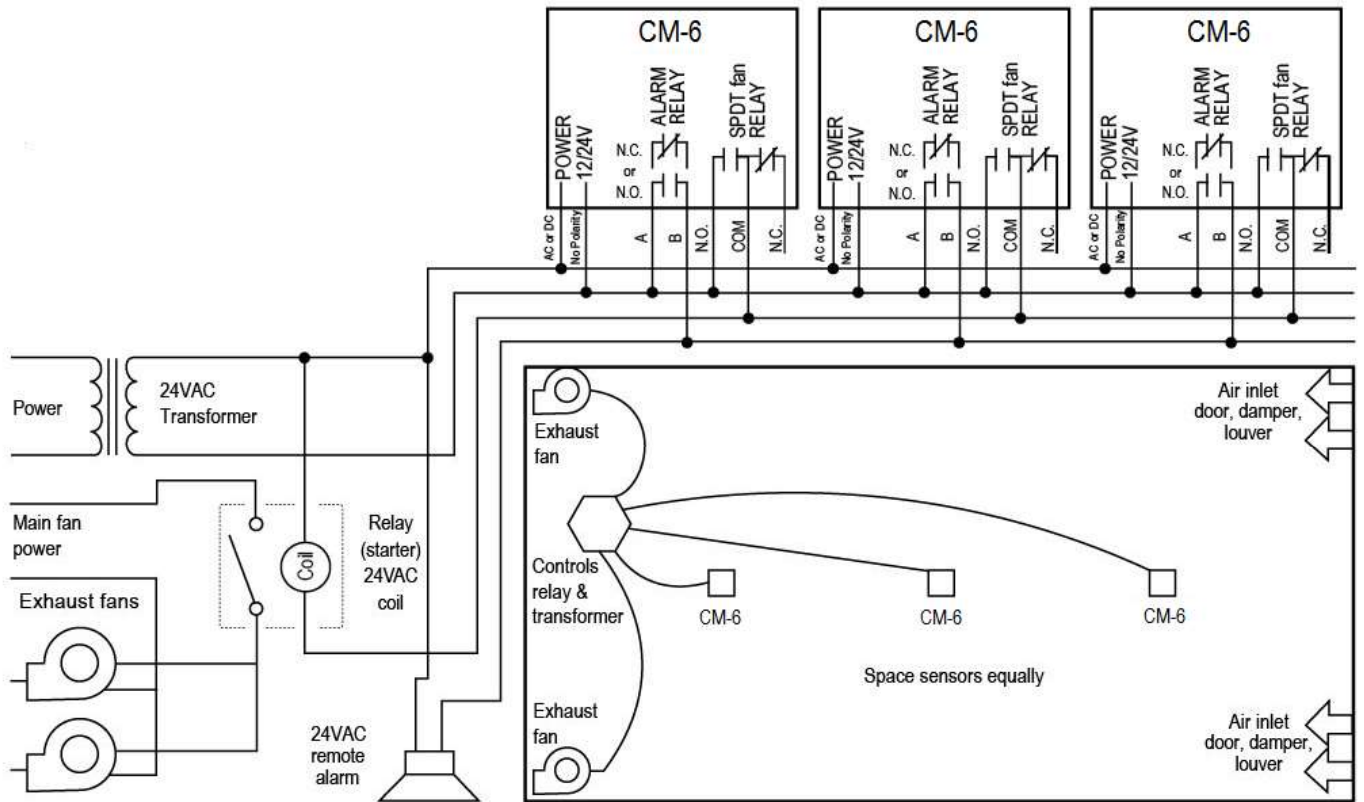

Figure 3-5 6-Series Multiple Device diagram

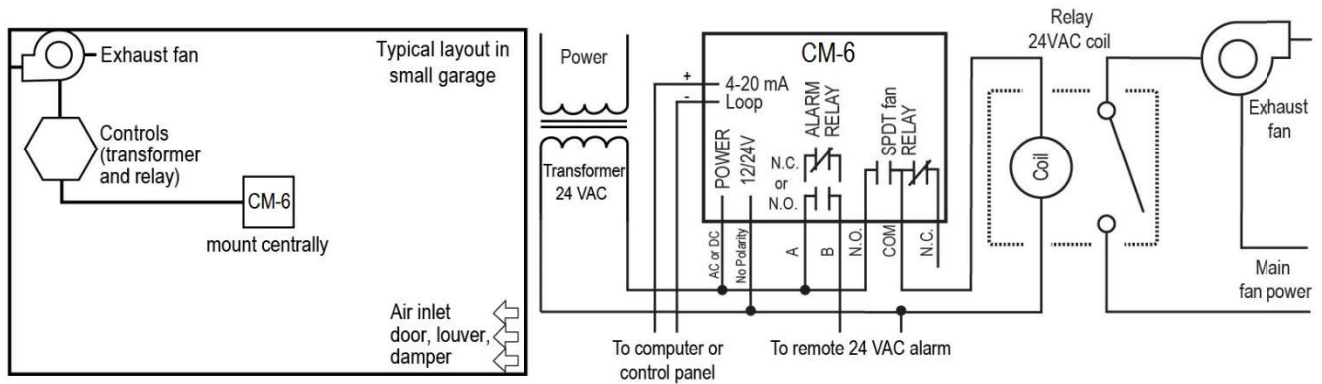

Figure 3-6 6-Series Stand Alone Diagram

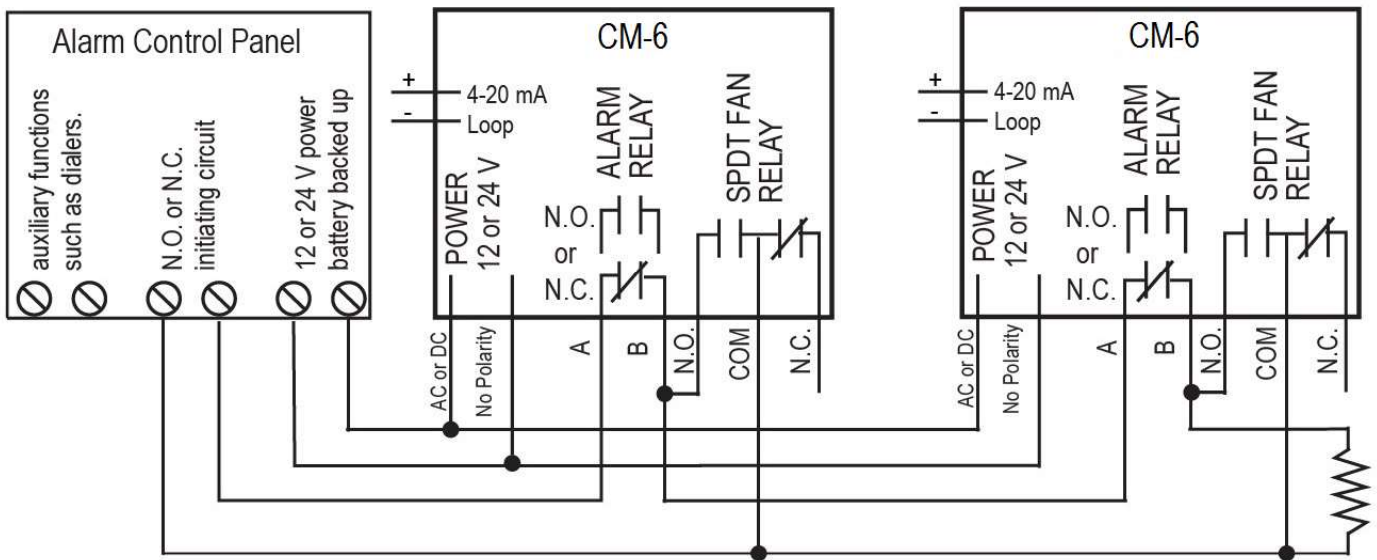

Figure 3-7 6-Series Alternate Alarm Panel

In this application (above) the Fan or primary relay is used as a low-level alarm relay. The Alarm or secondary relay is used as a supervisory relay when utilized in the normally closed configuration. The CM-6 monitors all critical functions of the unit through software diagnostics that continually test and verify its operations. If a problem is found, the unit will switch to a fail-safe/error mode or trouble condition. In this error mode the Fan\* and Alarm relays will be activated indicating the trouble condition at panel and the CM-6 display will flash the error. \*See section [4.5.11 Trouble Fan Settings – “tFS”](#) for options.

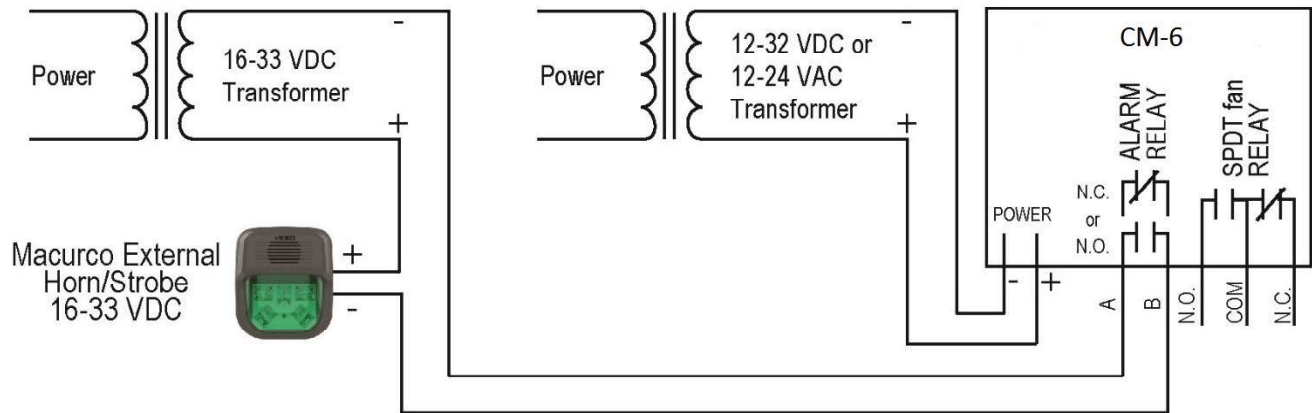

Figure 3-8 6-Series Horn & Strobe Combo Wiring

Macurco External Horn/Strobe model number is 78-2900-0211-X, where X represents lens color, R for red lens cover, G for green lens cover, B for blue lens cover, O for amber lens cover, C for clear lens cover. Sound pressure for Horn/Strobe model is at least 85dB at 10 feet.

NOTE: The final installation of CM-xx system, including secondary wiring from controller to sensors shall comply with requirements of “Class 1” in approved raceways or conduits.

### 3.2.2 12-Series Line Voltage

1. The CM-12 mounts on a 4” square (or 4x4) electrical box supplied by the contractor. Do not mount the CM-12 inside another box, unless it has good air flow through it.
2. There are two terminals for the dry alarm relay contacts, again with no polarity preference. The alarm relay can switch up to 0.5 A 120 V, or 60 VA. The alarm relay is activated if gas reaches or exceeds the alarm settings. See section [4.5 Default – Factory Settings](#) of this user manual for details on relay settings.
3. The alarm relay can be configured to normally open (default) (N.O.) or normally closed (N.C.) and will activate if the gas concentration exceeds alarm set point. It will deactivate once the gas concentration drops below the alarm set point. Note that the “disable” setting will cause the alarm relay not to engage at all.
4. The dry contact, SPDT fan relay has three terminals. The common (COM.), normally open (N.O.) and the normally closed (N.C.) contact. The fan relay can switch up to 5.0 A up to 240 VAC. See section [4.5 Default – Factory Settings](#) of this user manual for details on relay settings.
5. The Fan Relay can be configured for latching or non-latching (default) when activated (when the gas concentration exceeds fan relay set point). Once latched in, power will need to be interrupted or the “TEST” button pressed to unlatch the relay condition.
6. The Fan Relay will engage if the fan setting Carbon Monoxide concentration is exceeded for longer than the Fan Relay Delay time. Unless it is configured for latching, the fan relay will disengage once both of these conditions have been met:
  - Carbon Monoxide concentration has dropped below fan setting
  - Fan Relay Run time has been exceeded

Note that the “disable” fan setting will cause the fan relay to not engage. The fan relay will engage in trouble fault condition (if the Trouble Fan Setting Option is set to “ON”) and will disengage once trouble fault condition is cleared.

7. The Current Loop is 4 mA in clean air and 4-20 mA for 0-200ppm CO.

**NOTE:** 22 to 12 AWG wire shall be used. Wire used shall meet the temperature range of the detector i.e. 0°F to 125° F (-18°C to 52°C).

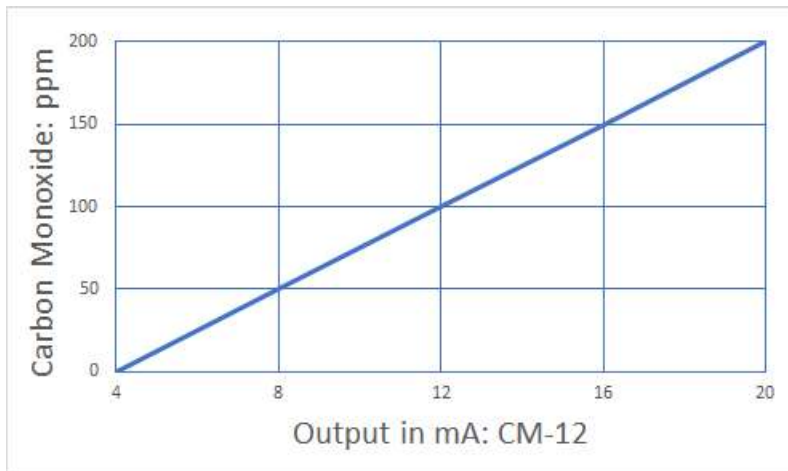

Figure 3-9 12-Series 4-20 mA Output Diagram

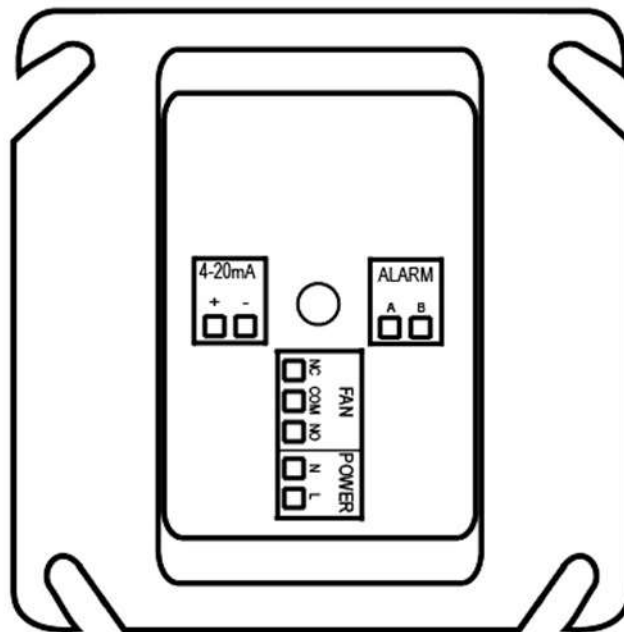

Figure 3-10 12-Series Rear View

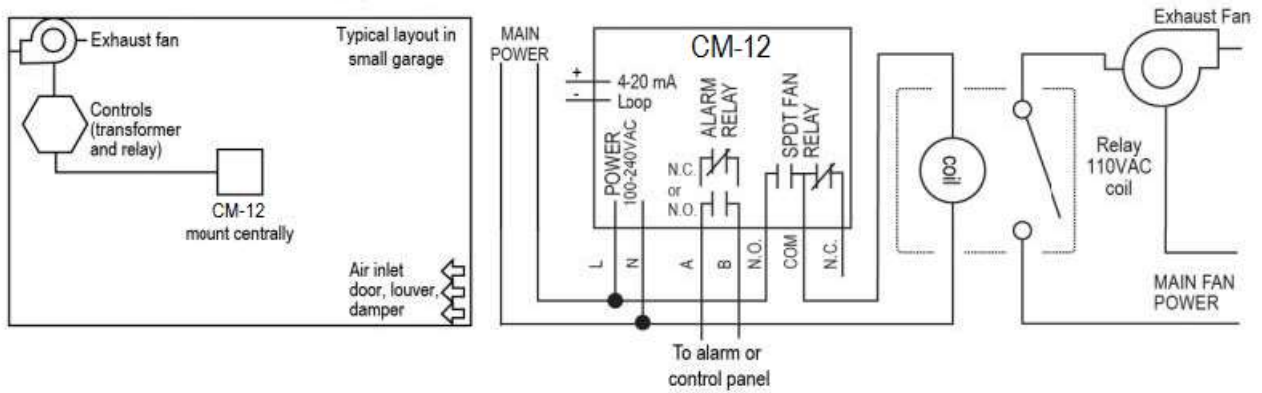

Figure 3-11 12-Series Stand Alone Diagram

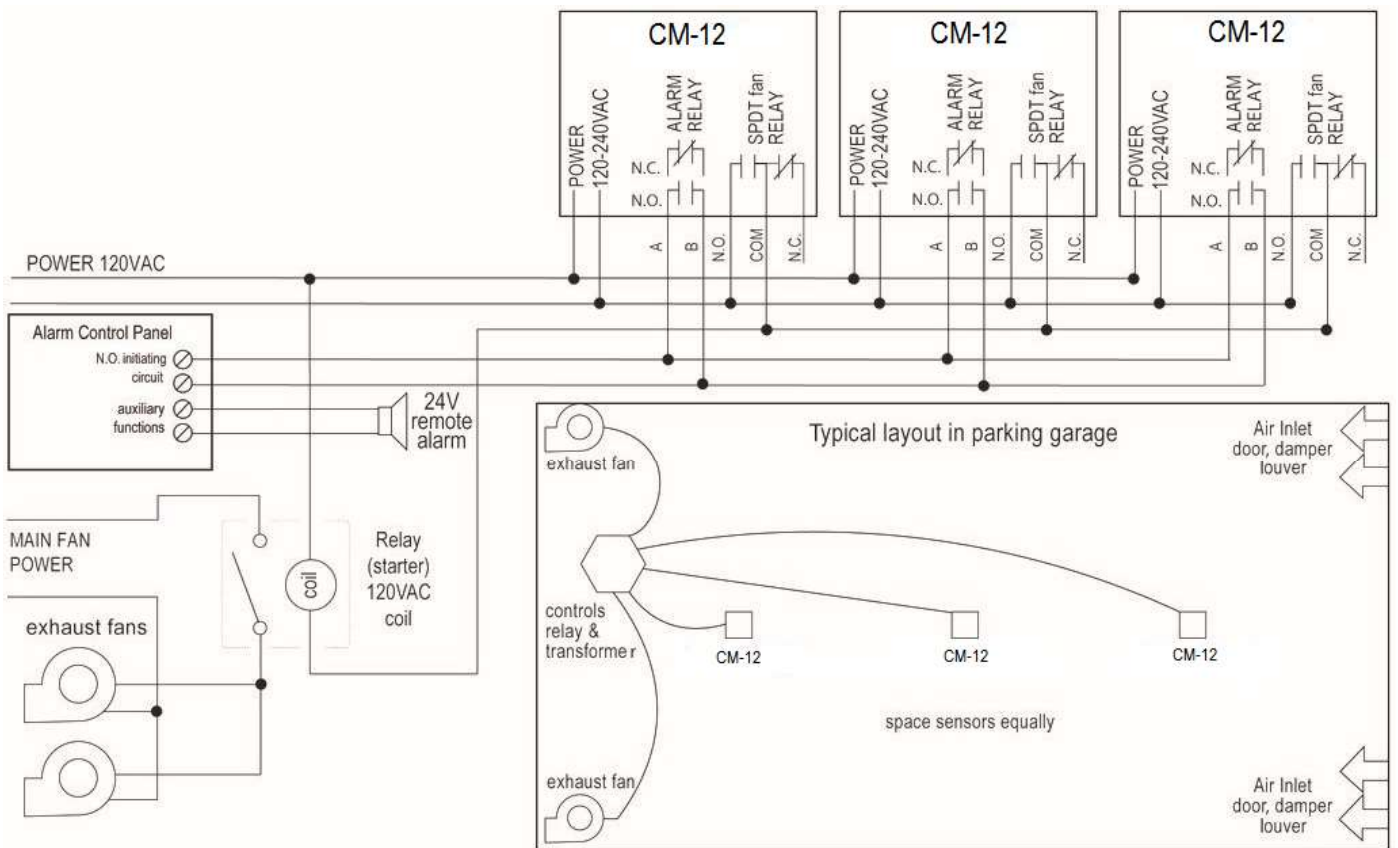

Figure 3-12 12-Series Multiple Device Diagram

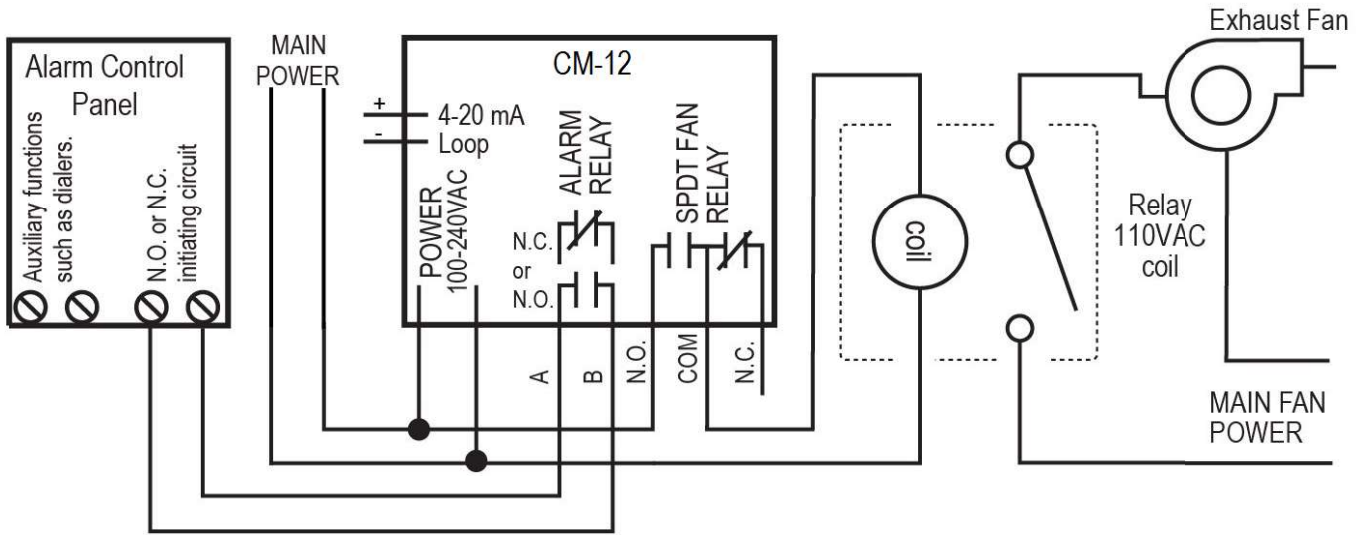

Figure 3-13 12-Series Alarm Control Panel Diagram

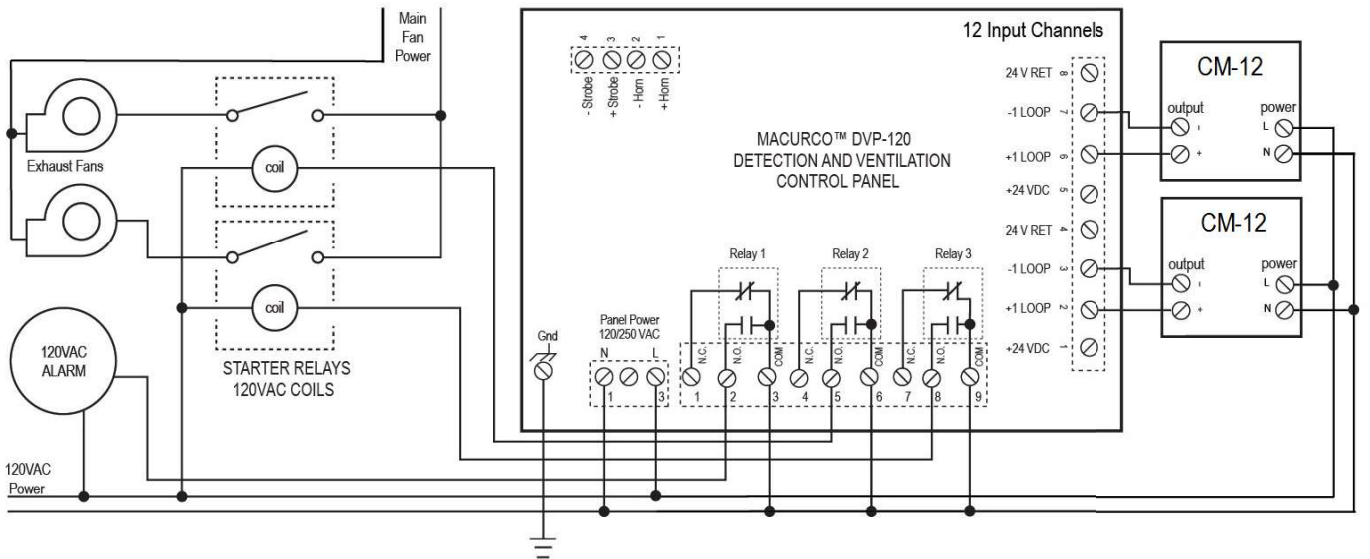

Figure 3-14 12-Series DVP-120 Control Panel Diagram

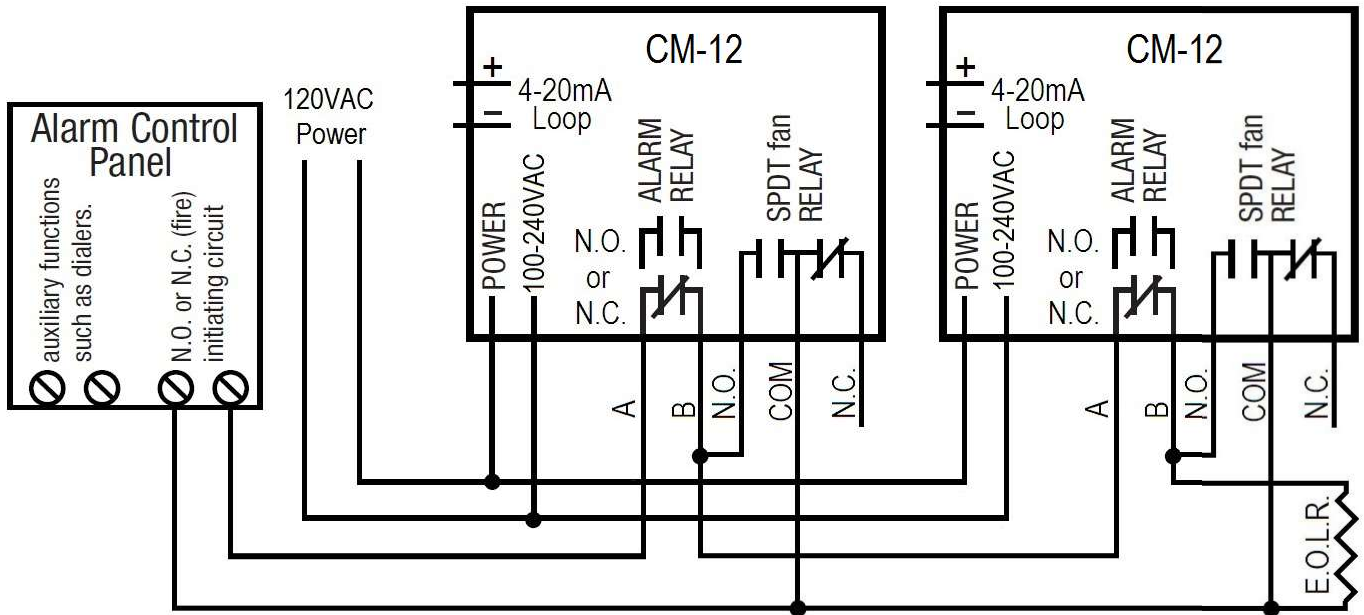

Figure 3-15 12-Series Alternate Alarm Panel

In this application (above) the Fan or primary relay is used as a low-level alarm relay. The Alarm or secondary relay is used as a supervisory relay when utilized in the normally closed configuration. The CM-12 monitors all critical functions of the unit through software diagnostics that continually test and verify its operations. If a problem is found, the unit will switch to a fail-safe/error mode or trouble condition. In this error mode the Fan\* and Alarm relays will be activated indicating the trouble condition at panel and the CM-12 display will flash the error. See section [4.5.11 Trouble Fan Setting – “tFS”](#) for options.

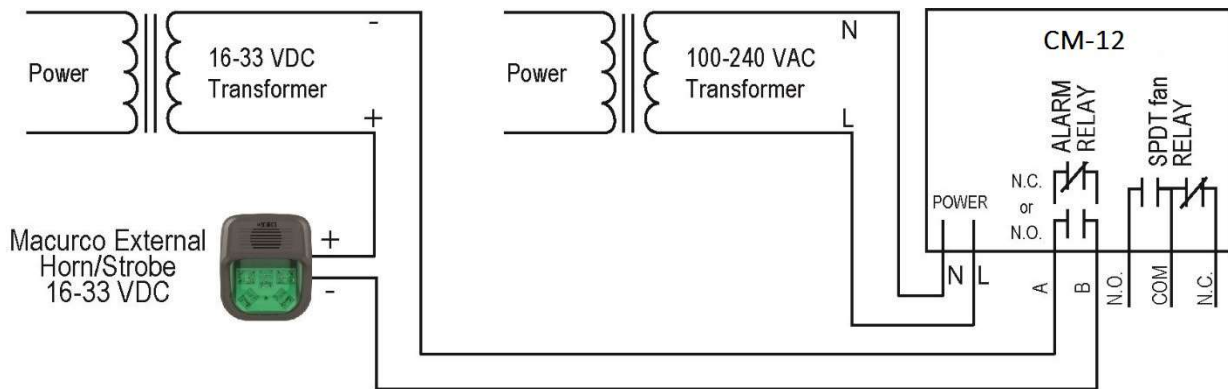

Figure 3-16 12-Series Horn & Strobe Combo Wiring



Macurco External Horn/Strobe model number is 78-2900-0211-X, where X represents lens color, R for red lens cover, G for green lens cover, B for blue lens cover, O for amber lens cover, C for clear lens cover. Sound pressure for Horn/Strobe model is at least 85dB at 10 feet.

NOTE: The final installation of CM-xx system, including secondary wiring from controller to sensors shall comply with requirements of “Class 1” in approved raceways or conduits.

### 3.3 Terminal Connection

#### 3.3.1 6-Series Low Voltage

With the exception of the safety ground, all field wiring is completed via modular connectors (provided). After wiring, simply plug the modular connectors into the matching connectors on the back side of the detector.

**NOTE:** 22 to 12 AWG wire shall be used. Wire used shall meet the temperature range of the detector i.e. 0°F to 125° F (-18°C to 52°C).

##### 3.3.1.1 Mains Power Connection

Connect the CM-6 to Class 2 power supply only. It is suggested to use a separate transformer for powering the unit or units because of possible interferences from other devices on the same power supply. Connect the CM-6 to the control cables with terminal plugs. When making connections, make sure the power is off. There are two terminals for Power: 12 to 24 VAC or 12 to 32 VDC, with no polarity preference

Ensure that the wire cannot be easily pulled from the connector. Plug the modular connection into the Fan/Power connection and ensure that it latches into the header properly.

##### 3.3.1.2 Fan Relay Connection

All of the SPDT Fan relay terminals are available at the Fan/Power modular connector. Each Fan relay terminal normally open, common and normally closed (NO, COM and NC) can accommodate a wire size 12 to 22 AWG. To install the wiring for the relays, disconnect the connector from the header. Strip the insulation of each wire back approximately 1/4 in. (6.5 mm), insert the bare wire into the terminal and tighten the screw clamp. Ensure that the wire cannot easily be pulled from the connector. Plug the modular connection into the Fan/Power connection and ensure that it latches into the header properly.

##### 3.3.1.3 Alarm Relay Connection

The external alarm connections (A and B) are available at the Alarm modular connector. There is no polarity for these connections. To install the wiring for the alarm contacts, disconnect the connector from the header on the detector. Strip the insulation of each wire back approximately 1/4 in. (6.5 mm), insert the bare wire into the terminal and tighten the screw clamp. Ensure that the wire cannot easily be pulled from the connector. When the wires are connected seat the modular connector into the header ensuring that the latch engages

##### 3.3.1.4 4-20 mA Signal Connection

The positive and negative 4-20mA signal connections (+ and -) are available at the 4-20mA modular connector, a 2-position connector. To install the wiring for the 4-20 mA contacts, disconnect the connector from the header on the detector. Strip the insulation of each wire back approximately 1/4 in. (6.5 mm), insert the bare wire into the terminal and tighten the screw clamp. Ensure that the wire cannot easily be pulled from the connector. When the wires are connected seat the modular connector into the header ensuring that the latch engages

#### 3.3.2 12-Series Line Voltage

With the exception of the safety ground, all field wiring is completed via modular connectors (provided). After wiring, simply plug the modular connectors into the matching connectors on the back side of the detector.

**NOTE:** 22 to 12 AWG wire shall be used. Wire used shall meet the temperature range of the detector i.e. 0°F to 125° F (-18°C to 52°C).



### 3.3.2.1 Mains Power Connection

Mains connections should be done in accordance with National and Local Electrical Codes. Only qualified personnel should connect Mains power to any device. Macurco recommends a minimum wire size of AWG18 and the wire insulator must be rated for 140°F (60°C) service. The modular connector will accept wire from 12 to 22 AWG.

The safety ground wire should be secured to the ground screw of the metal electrical box. Tighten the screw and make sure the wire is snug. Ensure that the wire cannot be pulled out from under the screw.

The Line (L) and Neutral (N) wires should be stripped 1/4 in. (6.5 mm), insert the wire into the "L" and "N" wire positions of the modular Fan/Power connector and tighten the screw clamp. Ensure that the wire cannot be easily pulled from the connector. Plug the modular connection into the Fan/Power connection and ensure that it latches into the header properly.

### 3.3.2.2 Fan Relay connection

All of the SPDT Fan relay terminals are available at the Fan/Power modular connector. Each Fan relay terminal normally open, common and normally closed (NO, COM and NC) can accommodate a wire size 12 to 22 AWG. To install the wiring for the relays, disconnect the connector from the header. Strip the insulation of each wire back approximately 1/4 in. (6.5 mm), insert the bare wire into the terminal and tighten the screw clamp. Ensure that the wire cannot easily be pulled from the connector. Plug the modular connection into the Fan/Power connection and ensure that it latches into the header properly.

### 3.3.2.3 Alarm Relay Connection

The external alarm connections (A and B) are available at the Alarm modular connector. There is no polarity for these connections. To install the wiring for the alarm contacts, disconnect the connector from the header on the detector. Strip the insulation of each wire back approximately 1/4 in. (6.5 mm), insert the bare wire into the terminal and tighten the screw clamp. Ensure that the wire cannot easily be pulled from the connector. When the wires are connected seat the modular connector into the header ensuring that the latch engages

### 3.3.2.4 4-20 mA Signal Connection

The positive and negative 4-20mA signal connections (+ and -) are available at the 4-20mA modular connector, a 2-position connector. To install the wiring for the 4-20 mA contacts, disconnect the connector from the header on the detector. Strip the insulation of each wire back approximately 1/4 in. (6.5 mm), insert the bare wire into the terminal and tighten the screw clamp. Ensure that the wire cannot easily be pulled from the connector. When the wires are connected seat the modular connector into the header ensuring that the latch engages

## 4 Operations

### 4.1 Power up

The CM-xx cycles through an internal self-test cycle for the first minute that it is powered. The unit will execute the test cycle any time power is dropped and reapplied (i.e. power failure). During the self-test cycle the unit will display the firmware version number, then count down from 60 to 0 (if the display setting is "On") and finally go into normal operation. The alarm relay will be activated for 10 seconds and the fan relay for 60 seconds during the power-up cycle unless the "Power Up Test" (PUT) option is OFF. The indicator light (LED) will flash green during the self-test cycle. If 4-20mA setting is set to "EnH", CM-xx will transmit information related to calibration period status via 4-20mA output during power-up cycle. At the end of the 1-minute cycle, the unit will take its first sample of the air and the indicator light will turn solid green.

### 4.2 Display turned "On"

Clean Air – With the display function turned "On", the CM-xx will show the current concentration of CO ppm or "0" (zero) in clean air.

Fan level – When the CO concentration reaches the Fan Relay setting (35 ppm, for example) the display will flash back and forth between "FAn" and "35" or current concentration of gas.



Alarm level – With the display function turned “On” and the CO concentration reaching the Alarm Relay setting, (200 ppm, for example) the display will flash back and forth between “ALr” and “200” or current concentration of gas. The buzzer will sound indicating “Alarm” if the buzzer is turned “On”.

Trouble – With the display function turned “On” and the device is in a trouble state, the display will display the “t” Error code (t01 for example). If the Trouble Fan Setting is enabled, the Fan relay will switch activating the relay. See section [4.5.11 Trouble Fan Setting – “tFS”](#) and section [5.1.2 “t” Error Codes](#) and

Calibration Due- With Calibration Period functionality enabled, if a detector is within 1 month of calibration period, then display will flash back and forth between “dUE” and current gas reading. Calibration Due is resolved only with successful field calibration.

### 4.3 Display turned “Off”

Clean Air – With the display function turned “Off”, the display does not show the CO concentration. Only the Power indicator light on will be on.

Fan Level – When the CO concentration reaches the Fan Relay setting (35ppm, for example) the display will show “FAn” continuously as long as the fan relay is enabled. This appears as slowly flashing “FAn”.

Alarm Level – With the display function turned off the display does not show the CO concentration but will show “ALr” when the Alarm relay is activated.

Trouble – With the display function turned “Off” and the device is in a trouble state, the display will display the “t” Error code (t01 for example). If the Trouble Fan Setting is enabled, the Fan relay will switch activating the relay. See Section [4.5.11 Trouble Fan Setting – “tFS”](#) and Section [5.1.2 “t” Error Codes](#).

Calibration Due- With Calibration Period functionality enabled, if a detector is within 1 month of calibration period, then display will show “dUE” continuously. Calibration Due is resolved only with successful field calibration.

### 4.4 4-20 mA Loop

4-20mA settings selected to ‘bAS’ or ‘EnH’ is considered as 4-20mA function turned ON.

Clean Air – With the 4-20 mA function turned “On” and the current concentration of CO ppm at “0” (zero), the 4-20mA loop will output 4 mA.

Gas read – With the 4-20 mA function turned “On” the output will read between 4 mA and 20 mA depending on the current concentration of CO.

Trouble – With the 4-20 mA function turned “On” and Trouble Fan Setting enabled. The 4-20mA loop will output 1 mA or 24 mA depending on the Trouble condition. See Section [5.1 On-Board Diagnostics](#).



### 4.5 Default – Factory Settings

The CM-xx comes pre-programmed with these default settings:

Setting:	Default:
<b>Power Up Test</b>	<b>On</b>
<b>Display</b>	<b>On</b>
<b>Buzzer</b>	<b>On</b>
<b>Alarm Relay Setting</b>	<b>200 ppm</b>
<b>Alarm Relay Configuration</b>	<b>Normally Open (NO)</b>
<b>Fan Relay Setting</b>	<b>35 ppm</b>
<b>Fan Relay Delay</b>	<b>3 minutes</b>
<b>Fan Relay Minimum Runtime</b>	<b>0 minutes</b>
<b>Fan Relay Latching</b>	<b>Off</b>
<b>Trouble Fan Setting</b>	<b>Off</b>
<b>4-20mA</b>	<b>bAS (basic)</b>
<b>Calibration due</b>	<b>dIS (disabled)</b>

To change settings, remove the Philips screw on the front of the CM-6. Pull off the front cover of the unit.

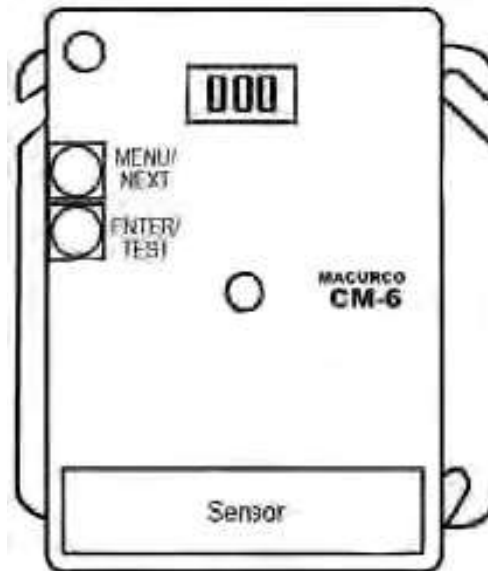

Figure 4-1 Board View

To reset the device to factory settings, see section 4.5.1 Selecting Default Configuration – “dEF”

#### 4.5.1 Selecting Default Configuration – “dEF”

To select the Default Configuration, in normal mode, push the **Next** button to get to “Con” or the Configuration menu. Then push the **Enter** button to enter the Con menu. The first selection is the “dEF” or Default setting. Push **Enter**. If it is already in Default configuration, there will be no action. If it is not already in Default configuration, “nO” will be displayed. Push Next to

change it to “YES” (flashing) then push **Enter** to confirm the change (solid) and push **Enter** again to return to “dEF” in the con menu. Push **Next** until “End” is displayed then push **Enter** to get back to normal operation.

**Note:** This menu cannot be changed when CM-XX is in calibration due or calibration overdue. (Refer to Section [4.5.13 Calibration Period Settings – “CAL”](#) for information on calibration due and calibration overdue.)

#### 4.5.2 Power-Up Test Setting – “PUt”

To select the Power Up Test Configuration, in normal mode, push the **Next** button to get to “Con” or the Configuration menu. Then push the **Enter** button to enter the Con menu. Then push the **Next** button to get to the second selection “PUt” or Power Up Test setting. Push **Enter**. If the testis “On” push **Next** to turn it “OFF” (flashing) then push **Enter** to confirm the change (solid) and push **Enter** again to return to “PUt” in the Con menu. Push **Next** until “End” is displayed then push **Enter** to get back to normal operation.

#### 4.5.3 Display Setting – “dSP”

To select the Display Configuration, in normal mode, push the **Next** button to get to “Con” or the Configuration menu. Then push the **Enter** button to enter the Con menu. Then push the **Next** button to get to the third selection “dSP” or Display setting. Push **Enter**. If the display is “On” push **Next** to turn it “OFF” (flashing) then push **Enter** to confirm the change (solid) and push **Enter** again to return to “dSP” in the Con menu. Push **Next** until “End” is displayed then push **Enter** to get back to normal operation.

#### 4.5.4 Buzzer Setting – “bUZ”

To select the Buzzer Configuration, in normal mode, push the **Next** button to get to “Con” or the Configuration menu. Then push the **Enter** button to enter the Con menu. The forth selection is the “bUZ” or Buzzer setting. Push **Next** twice to get to “bUZ” then **Enter**. If the display is “On” push **Next** to turn it “OFF” (flashing) then push **Enter** to confirm the change (solid) and push **Enter** again to return to “bUZ” in the Con menu. Push **Next** until “End” is displayed then push **Enter** to get back to normal operation.

#### 4.5.5 Alarm Relay Setting – “ArS”

To select the Alarm Relay Setting, in normal mode, push the **Next** button to get to “Con” or the Configuration menu. Then push the **Enter** button to enter the Con menu. The fifth selection is the “ArS” or Alarm Relay Setting. Push **Next** three times to get to “ArS” then **Enter**. If the display is “dIS” (disabled) push **Next** to change it to 50, 100, 150 or 200 ppm (flashing) then push **Enter** to confirm the change (solid) and push **Enter** again to return to “ArS” in the Con menu. Push **Next** until “End” is displayed then push **Enter** to get back to normal operation.

#### 4.5.6 Alarm Relay Configuration – “Arc”

To select the Alarm Relay Configuration, in normal mode, push the **Next** button to get to “Con” or the Configuration menu. Then push the **Enter** button to enter the Con menu. The sixth selection is the “Arc” or Alarm Relay Configuration. Push **Next** four times to get to “Arc” then **Enter**. If the relay is “nO” (normally open) push **Next** to turn it to “nC” (flashing) then push **Enter** to confirm the change (solid) and push **Enter** again to return to “Arc” in the Con menu. Push **Next** until “End” is displayed then push **Enter** to get back to normal operation.

#### 4.5.7 Fan Relay Setting – “FrS”

To select the Fan Relay setting, in normal mode, push the **Next** button to get to “Con” or the Configuration menu. Then push the **Enter** button to enter the Con menu. The seventh selection is the “FrS” or Fan Relay setting. Push **Next** five times to get to “FrS” then **Enter**. If the fan relay is “dIS” (disabled) push **Next** to change it to 15, 25, 35, 50 or 100 ppm (flashing) then push **Enter** to confirm the change (solid) and push **Enter** again to return to “FrS” in the Con menu. Push **Next** until “End” is displayed then push **Enter** to get back to normal operation.

#### 4.5.8 Fan Relay Delay Setting – “Frd”

To select the Fan Relay Delay setting, in normal mode, push the **Next** button to get to “Con” or the Configuration menu. Then push the **Enter** button to enter the Con menu. The eighth selection is the “Frd” or Fan Relay Delay. Push **Next** six times to get to



“Frd” then **Enter**. If the delay is “0” (disabled) push **Next** to change it to 1, 3, 5, or 10 minutes (flashing) then push **Enter** to confirm the change (solid) and push **Enter** again to return to “Frd” in the Con menu. Push **Next** until “End” is displayed then push **Enter** to get back to normal operation.

#### 4.5.9 Fan Relay Minimum Runtime Setting – “Frr”

To select the Fan Relay Minimum Runtime setting, in normal mode, push the **Next** button to get to “Con” or the Configuration menu. Then push the **Enter** button to enter the Con menu. The ninth selection is the “Frr” or Fan Minimum Run Time. Push **Next** seven times to get to “Frr” then **Enter**. If the runtime is “0” (disabled) push **Next** to change it to 3, 5, 10 or 15 minutes (flashing) then push **Enter** to confirm the change (solid) and push **Enter** again to return to “Frr” in the Con menu. Push **Next** until “End” is displayed then push **Enter** to get back to normal operation.

#### 4.5.10 Fan Relay Latching Setting – “FrL”

To select the Fan Relay Latching Option, in normal mode, push the **Next** button to get to “Con” or the Configuration menu. Then push the **Enter** button to enter the Con menu. The tenth selection is the “FrL” or Fan Relay Latching Option. Push **Next** nine times to get to “FrL” then **Enter**. If latching is “OFF” push **Next** to turn it to “ON” (flashing) then push **Enter** to confirm the change (solid) and push **Enter** again to return to “FrL” in the Con menu. Push **Next** until “End” is displayed then push **Enter** to get back to normal operation.

#### 4.5.11 Trouble Fan Setting – “tFS”

To select the Trouble Fan Setting Option, in normal mode, push the **Next** button to get to “Con” or the Configuration menu. Then push the **Enter** button to enter the Con menu. The eleventh selection is the “tFS” or Trouble Fan Setting Option. Push **Next** ten times to get to “tFS” then **Enter**. If Trouble Fan Setting is “OFF” push **Next** to turn it to “ON” (flashing) then push **Enter** to confirm the change (solid) and push **Enter** again to return to “tFS” in the Con menu. Push **Next** until “End” is displayed then push **Enter** to get back to normal operation.

#### 4.5.12 4-20mA Output setting – “420”

To select the 4-20mA Output Option, in normal mode, push the **Next** button to get to “Con” or the Configuration menu. Then push the **Enter** button to enter the Con menu. The twelfth selection is the “420” or 4-20mA Output Option. Push **Next** eleven times to get to “420” then **Enter**. If the 4-20mA is “bAS” push **Next** to turn it to “EnH” (flashing) and push **Next** one more time to turn it to “OFF” (flashing). Then push **Enter** to confirm the change (solid) and push **Enter** again to return to “420” in the Con menu. Push **Next** until “End” is displayed then push **Enter** to get back to normal operation.

NOTE: CM-XX will transmit information about calibration period to Macurco Control Panel (via 4-20 mA output) only when 4-20mA output setting is set to ‘EnH’.

#### 4.5.13 Calibration Period Settings – “CAL”

Value selected in Calibration Period settings is number of months. CM-xx indicates a “calibration due” when it is within 1 month of calibration period, and “calibration overdue” when detector has reached or exceeded calibration period. Calibration Period Settings cannot be changed if CM-xx is indicating “calibration due” or “calibration overdue”.

To select the Calibration Period Option, in normal mode, push the **Next** button to get to “Con” or the Configuration menu. Then push the **Enter** button to enter the Con menu. The thirteenth selection is “CAL” or Calibration Period setting. Push **Next** twelve times to get to “CAL” then push **Enter**. Default setting is “DIS”. Push **Next** to change it to 3, 6, 12 or 24 (flashing) then push **Enter** to confirm the change (solid). Then push **Enter** again to return to “CAL” in the Con menu. Push **Next** until “End” is displayed then push **Enter** to get back to normal operation.



## 5 Troubleshooting

### 5.1 On-Board Diagnostics

The CM-xx monitors all critical functions of the unit through software diagnostics that continuously test and verify unit operations. If a problem is found, the unit will switch to a fail-safe/error mode or trouble condition. In this error mode, the Alarm relay will be activated, the 4-20 mA current loop will go to 24 mA, the unit will display the error code, the green status indicator LED light will flash, and the buzzer will chirp intermittently. The Fan relay will also engage if the Trouble Fan Setting Option is set to "ON". This is a safety precaution. To clear this mode, simply turn off power to the unit for a few seconds or push the ENTER/TEST switch (inside the unit). This will cause the unit to restart the 1-minute self-test cycle.

#### 5.1.1 4-20mA troubleshooting

- 0 mA is most likely a connection problem
- 1 mA indicates Calibration Overdue (if 4-20mA is configured to 'EnH')
- 4-20 mA is normal gas reading range (0-200 ppm)
- 24 mA indicates a Trouble condition

#### 5.1.2 "t" error codes

tXX	
t01	Sensor Fatal Error/ Sensor missing
t02	Temperature compensation failure
t04	EEPROM bad checksum
t08	Sensor is shorted
t10	Bad EEPROM
t20	Bad calibration
t40	Factory calibration failure
t80	Read ADC failure
t100	Under range
t200	Sensor expired / End of Life
t8000	Calibration Overdue

**NOTE:**

- I. T8000 has highest priority among all trouble code i.e. if T8000 error code exist along with other 't' error code then the 4-20mA output is 1mA if T8000 exist.
- II. T8000 is resolved only with successful field calibration.
- III. If there are multiple error codes existing at the same time, the displayed code will be the sum of error codes. E.g. Unit will display t03 if t01 and t02 exist at same time, t180 if t100 and t80 exist at the same time etc.

If the sum for a digit (ones, tens or hundreds) is greater than 9, it will display corresponding hexadecimal representation of the sum. Following table shows the hexadecimal representation for number from 10 to 15.

Decimal Number	Hexadecimal Representation displayed on UNIT
10	A
11	b
12	C
13	d
14	E
15	F

Table 5-1 Hexadecimal Display

E.g. unit will display t0A if t02 and t08 exist at same time. Similarly, tC0 if t40 and t80 exist at the same time.

For trouble codes over 2 digits, the display will alternate ‘tXX’ and ‘t.YY’ where XX corresponds to first two digits and YY (note ‘.’ after ‘t’) corresponds to last two digits of trouble code. E.g. the display will alternate between t01 and t.00 for t100, t02 and t.00 for t200 and t80 and t.00 for t8000.

If the error mode repeats frequently, check for continuous power and proper voltage. If power is not the problem and a unit has repeating error conditions, it may need to be returned to Macurco for service, per these User Instructions.

If the error mode indicates “Sensor expired” see the Sensor Life Reset section of these User Instructions

## 5.2 Sensor Poisons

The sensor in the detector is designed with extreme sensitivity to the environment. As a result, the sensing function may be deteriorated if it is exposed to contaminants, a direct spray from aerosols such as paints, silicone vapors, etc., or to a high density of corrosive gases (such as hydrogen sulfide, sulfur dioxide) for an extended period of time.

## 5.3 End-of-Life Signal

The CM-xx has a long life, non-replaceable electrochemical sensor. Ten (10) years after the CM-xx is installed the sensor end-of-life signal will be activated indicating that the CM-xx has reached the end of its typical usable life. The end-of-life signal will cause an error code t200 “Sensor expired”. See Section 5.1.2 “t” Error Codes.

The end-of-life signal can be silenced for 48 hours by pressing the "ENTER/TEST" button or by temporarily dropping power to the unit. The end-of-life signal provides the user an opportunity to test and/or calibrate the sensor assuring that it is still performing within acceptable parameters though the sensor is nearing the end of its expected life. The silence function will continue to be available for 29 days after the CM-xx initiates the initial end-of-life signal. After this 29-day period the CM-xx can no longer be silenced, and the sensor must be calibrated, and the sensor life reset, or the CM-xx detector replaced.

# 6 Maintenance

The CM-6 is low maintenance. The unit uses a long-life electrochemical sensor that has a 10-year life expectancy (in normal conditions). The detector’s performance should be tested regularly by using gas as detailed in the Testing and Field Calibration sections. All maintenance and repair of products manufactured by Macurco are to be performed at the appropriate Macurco manufacturing facility. Macurco does not sanction any third-party repair facilities

## 6.1 Sensor Life Reset

1. Remove the Philips screw on the front of the CM-xx. Pull the front cover of the unit off.
2. To reset the sensor life (rSt), from normal or warm-up mode, press the **Next** button four times to get to “SEn” or Sensor Mode.
3. Then press the **Enter** button to get to “rSt” - Reset Sensor Mode.



4. Press the **Enter** button again to see the sensor reset status. If the sensor life has already been reset, done “don” will be displayed. If it has not already been reset, “no” will be displayed. Push Next to change it to “YES” (flashing) then push **Enter** to confirm the change (solid) and push Enter again to return to “rSt” in the “SEn” menu. Push **Next** until “End” is displayed then push **Enter** to get back to normal operation. The sensor life will be reset for 1 year.

**NOTE:** If the sensor is reset and the detector not replaced, it is necessary to test and/or calibrate the sensor to assure that it is still performing within acceptable specifications though the sensor is nearing the end of its expected life. There will be no other indication of sensor performance.

 <b>WARNING</b>
Do not disassemble unit or attempt to repair or modify any component of this instrument. This instrument contains no user serviceable parts, and substitution of components may impair product performance.

**CAUTION**

Avoid the use of harsh cleaning materials, abrasives and other organic solvents. Such materials may permanently scratch the surfaces and damage the display window, labels, sensor or instrument housing. High voltage terminals (100-240VAC) are located within this detector, presenting a hazard to service technicians. Only qualified technicians should open the detector case and service the internal circuits. Ensure power is removed from the detector prior to cleaning the unit. Failure to do so may result in sickness or death.

## 6.2 Cleaning

Cleaning of the external surfaces is best carried out using a damp cloth with a mild detergent or soap. Use a vacuum cleaner with soft brush to remove dust or contamination under the cover. Do not blow out the sensor with compressed air.

## 7 Testing

 <b>WARNING</b>
Using a certified gas with a concentration other than the one listed for this detector when conducting a calibration verification test (bump test) will produce inaccurate readings. This means that higher levels of the gas being monitored may be present and could result in overexposure. For proper use, see supervisor or User manual, or contact Technical Support at 1-844-325-3050.

All CM-6 units are factory calibrated, 100% tested for proper operation and accuracy of  $\pm 10\%$ \*. During normal operation the green status indicator LED light will be on steady, the fan & alarm relay will be in standby mode and the 4-20 mA output will be at 4mA (in clean air). The unit also performs a regular automatic self-test during normal operation. If the unit detects an improper voltage or inoperable component, it will default into Error mode. In this error mode, the Alarm relay will be activated, the 4-20 mA current loop will go to 24 mA, the unit will display the error code, the green status indicator LED light will flash, and the buzzer will chirp intermittently. The Fan relay will also engage if the Trouble Fan Setting Option is set to “ON”.

\*Tested at 100ppm CO at 68°F to 75°F.

## 7.1 Testing

### 7.1.1 Operation Test

Check that the green CM-6 status indicator LED light is illuminated continuously. If not, do not proceed with the tests. If the unit is in error mode, contact your local representative or Macurco technical service representative for information on resolving the problem.

1. Remove the single screw in the middle of the front cover of the CM-6.
2. Remove the front cover.
3. Observe the LED light on the front of the CM-6.
4. If the light is solid green proceed to step 6.
5. If the green status indicator LED light is off or flashing, refer to the General section above.
6. Locate the switch labeled ENTER/TEST on the left side of the printed circuit board. Press the Test switch once.
7. The CM-6 will step through a cycle test:
  - a. The display progresses through the BUZ (Buzzer Test) Art (alarm relay test), Frt (fan relay test) then 42t (4-20 mA output test). Make sure that the settings are “on” or not disabled “diS”.
  - b. During the first 3 seconds of the test cycle, the display will show BUZ and set off the audible buzzer
  - c. The alarm relay will be closed for 5 seconds, any devices connected to that relay will be tested.
  - d. The Fan relay will be activated for the next 1 minute of the test, so if the fan circuits are wired in the normal manner, the fan should run.
  - e. The 4-20mA output will then ramp up from 4 to 16 mA over the next 130 seconds of the test, so if the circuit is wired in the normal manner, the control panel or building automation system should respond.
  - f. At the end of the test cycle, the fan & alarm relay will be in standby mode and the 4-20 mA output will return to 4 mA (in clean air).
8. When testing is completed reassemble the unit or units.

### 7.1.2 Manual Operation Test

This option gives the user the opportunity to manually initiate an individual test for each relay, the analog output and the sensor response to gas. From normal operation mode press the Next button 2 times to get to the Test Mode (tSt). Press the Enter button once to get into the Test Menu. Press the Next button to scroll through the five test options and press Enter to initiate the selected test. Note that if the relay or 4–20 mA output has been disabled, the test selection will not be displayed in the test menu.

**bUZ**- Buzzer Test, 3 seconds

**Art** - Alarm Relay Test, 5 seconds

**FrT** - Fan Relay Test, 60 seconds

**42t** - 420 loop test, 130 seconds

**gtS** - Gas Test, 3 minutes (no output to the panel during the gas test)

The display will flash during the test, or in the case of the gas test, the gas level will alternate with gtS. Once the test is complete, the display will return to steady display. To exit the test menu, press the **Next** button until “End” is displayed then, press **Enter** to return to normal mode.



## 7.2 Calibration and Test Kits

### **WARNING**

The following steps must be performed when conducting a calibration or calibration verification test (bump test) to ensure proper performance of the monitor. Failure to do so may adversely affect product performance.

- When performing a calibration or calibration verification test (bump test) only use certified calibration gas at the required concentration level.
- Do not test with expired calibration gas.
- Do not cover or obstruct display or visual alarm cover.
- Ensure sensor inlets are unobstructed and are free of debris

Failure to follow instructions outlined in this user manual can result in sickness or death.

- When performing a calibration or calibration verification test (bump test) only use certified calibration gas at the required concentration level. Do not calibrate with expired calibration gas.
- If the instrument cannot be calibrated, do not use until the reason can be determined and corrected.
- Do not cover or obstruct display or visual alarm cover.
- Ensure sensor inlets are unobstructed and is free of debris

A Field Calibration Kit, Cal-Kit 1, and one bottle of calibration gas is needed to complete gas test. These are available through local distribution or from Macurco.

**NOTE:** CM-xx must be tested or calibrated at regular intervals in accordance with the requirements of the National Fire Protection Association (NFPA) 720 or local code requirements. It is recommended to test or calibrate CM-xx at least annually.

#### Contents of the Cal-Kit 1

- Cal-Kit 1 (30-0011-1110-2)
  - Calibration Case
  - Two feet of Tygon tubing
  - Cal Hood-Macurco Pack
  - 0.2 LPM Gas regulator (F)

Also needed are the following gas bottles (Sold Separately):

- Qty 1 CO-200PPM (70-0714-0348-2) Carbon Monoxide CO Cal Gas Cylinder 17L 200 ppm (M) **(For Calibration)**
- Qty 1 CO-50PPM (70-0714-8640-4) Carbon Monoxide CO Cal Gas Cylinder 17L 50 ppm (M) **(For Gas Testing)**

#### Cal-Kit 1 Information

Several detectors can be calibrated with one Cal-Kit. The only limitation is the amount of gas in the cylinder. The 17-liter cylinder has approximately 85 minutes of continuous calibration run time. The gas cylinder should be replaced when the pressure gauge on the regulator shows 25-psi or less.

**Note:** For optimum test results it is suggested that the unit be in clean air, green light on, and be in a low ambient air flow.



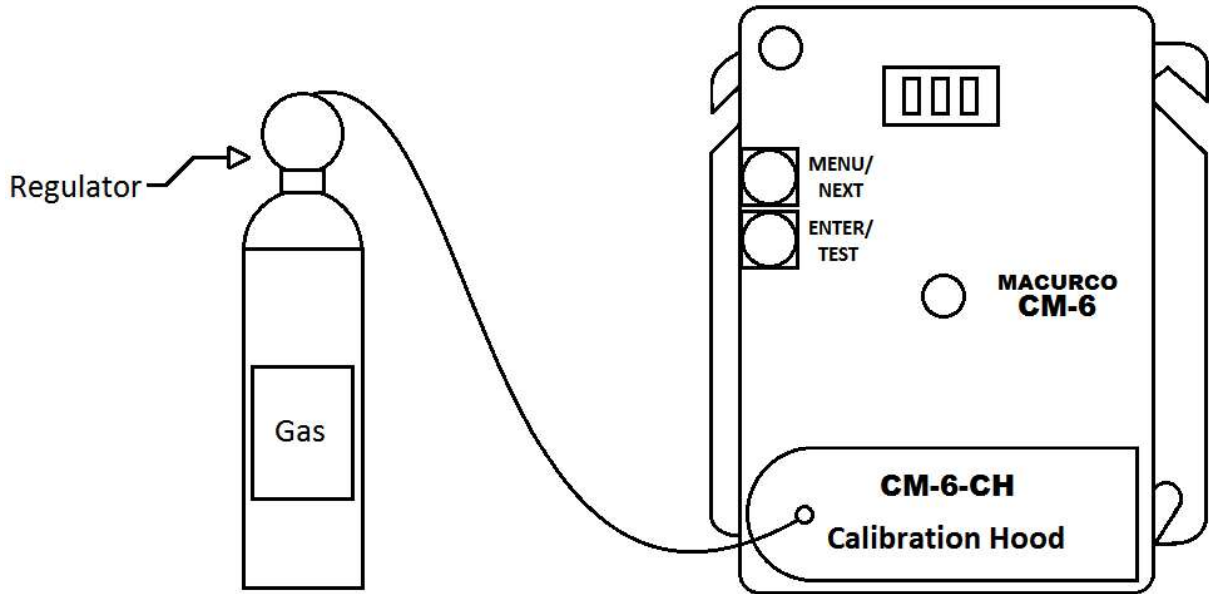

Figure 7-1 Calibration Kit Connection

## 7.3 Gas Testing

### 7.3.1 Testing the Fan Relay

1. Remove the Philips screw on the front of the CM-6. Remove the front cover.
  2. Open the Cal-Kit 1. Connect the 50-ppm gas cylinder to the regulator.
  3. Check the pressure gauge on the regulator. If you have 25-psi or less, you will need to replace the gas canister.
  4. Assemble regulator, hose and Test Hood and place the Test Hood over the CO sensor.
- Note:** The time to activate the Fan relay depends on the delay setting.
5. Turn on the regulator to start the gas flow and wait with the gas applied continuously.
  6. With the display function turned “On”, the CM-6 will show the current concentration of CO or “0” (zero) in clean air. When the CO concentration reaches the Fan Relay setting (35 ppm, for example) the display will flash back and forth between “FAn” and “current gas reading”. With the display function turned “Off”, the display does not show the CO concentration, but will show “FAn” as long as the fan relay is activated.

**Note:** If the Fan relay does not close within 2 minutes, there are four possibilities:

- a. Gas cylinder is empty, check the pressure gauge. Replace the gas cylinder if 25psi or less.
  - b. Unit needs to be re-calibrated (go through recalibration and re-test).
  - c. Detector is in need of servicing (return unit to factory for servicing).
  - d. Detector has fan relay set to disable (diS) or 100ppm. Set fan relay to 25ppm and repeat the test.
7. Remove the gas from the sensor. Proceed to Test the Alarm relay or replace the top cover.

### 7.3.2 Testing the Alarm Relay

**Note:** The CO concentration to activate the Alarm relay depends on the setting.

1. Connect the 200ppm cylinder of carbon monoxide to the regulator.
2. Check the pressure gauge. If there is 25psi or less the cylinder should be replaced.
3. Place the Test Hood over the CO sensor. Turn on the regulator to start the gas flow.
4. The Fan relay should activate according to the settings.
5. With the display function turned “On” and the CO concentration reaching the Alarm Relay setting, (200 ppm, for example) the display will flash back and forth between “ALr” and “current gas reading”. The buzzer will sound

indicating “Alarm” if the buzzer is turned “On”. With the display function turned off the display does not show the CO concentration but will show “ALr” when the Alarm relay is activated.

**Note:** If the Alarm relay fails to operate within 2 minutes, there are four possibilities:

- a. Gas cylinder is empty, check the pressure gauge. Replace the gas cylinder if 25-psi or less.
  - b. Unit needs to be re-calibrated (go through recalibration and re-test).
  - c. Detector is in need of servicing (return unit to factory for servicing).
  - d. Detector has Alarm relay set to disable (diS). Set Alarm relay to 100 ppm and repeat the test.
6. Remove the gas from the sensor after Test. Proceed to Test the 4-20mA output or replace the top cover.

### 7.3.3 Testing the 4-20mA loop

1. Connect the 200-ppm cylinder of carbon monoxide to the regulator.
2. Check the pressure gauge. If there is 25-psi or less the cylinder should be replaced.
3. Place the cap from the regulator over the CO sensor. Turn on the regulator to start the gas flow.
4. The Fan relay should activate according to the settings.
5. The Alarm relay should activate according to the settings.
6. The 4-20 mA output should ramp up from 4mA in clean air to 20mA at 200 ppm. See 4-20 mA diagram on page 6.

**Note:** If the 4-20mA output does not ramp up within 2 minutes, there are four possibilities:

- a. Gas cylinder is empty, check the pressure gauge. Replace the gas cylinder if 25-psi or less.
  - b. Unit needs to be re-calibrated (go through recalibration and re-test).
  - c. Detector is in need of servicing (return unit to factory for servicing).
  - d. Detector has 4-20 mA option set to “OFF”. Set 4-20mA option to “On” and repeat the test.
7. Remove the gas from the sensor. Re-assemble the CM-6 (make sure the LED is aligned with the front case hole). You are done.

### 7.3.4 Aerosol Carbon Monoxide Test

The CME1-FTG is an 11L 500 ppm Aerosol Carbon Monoxide Field Test Gas that can be used with the CM-xx. This field test gas allows installers to do a quick functionality test of the CO sensor. The flow rate of the CME1-FTG is 10 Lpm so you will have about a minute of gas or enough to test 20-30 sensors.

1. Units to be tested must be powered continuously for a minimum of 3 minutes before proceeding.
2. For optimum test results the unit should be in clean air and be in a low ambient air flow.
3. Check that the CM-6 status indicator light is illuminated, Green continuously. If not, do not proceed with tests. See CM-6 Onboard Diagnostics section.
4. The display option should be set to “On” and reading 0 ppm in clean air.
5. With the CM-6 cover on, aim the nozzle of the aerosol can into the sensor grate area (under DO NOT PAINT) and press for 2 to 3 seconds.
6. Wait for a few seconds. The digital display should climb indicating the increased CO concentration at the sensor confirming a pass of the quick test.

**Note:** If the Display does not change within 10 seconds, there are four possibilities:

- a. Gas cylinder is empty, replace the gas cylinder.
  - b. Unit needs to be re-calibrated (go through the Field Calibration Procedure and re-test).
  - c. Detector is in need of servicing (return unit to factory for servicing).
7. Wait for the display to return to 0 ppm and configure options to desired settings.

## 7.4 Field Calibration Procedure

**Note:** For optimum calibration results the unit should be in clean air and be in a low ambient air flow.



CM-xx has “CAL” top level menu that can be used to perform field calibration. ‘tSC’, ‘Spn’ and ‘End’ are sub-menu within “CAL” menu. ‘tSC’ is read only menu and represents the time since last calibration. If you enter this sub-menu, it will display value in format Y.MM. “MM” are for months and “Y” for year. E.g. if the value is 0.05 then it has been 5 months since the unit was last calibrated. ‘Spn’ sub-menu is used during field calibration procedure as described in following procedure. ‘End’ sub-menu is used to exit out of ‘CAL’ menu.

Follow the procedure below for field calibration.

- a. Remove the Philips screw on the front of the CM-xx. Pull the front cover of the unit off.
- b. Assemble the 200-ppm gas cylinder and regulator together.
- c. Check the pressure gauge on the regulator. If you have 25-psi or less you will need to replace the gas canister.
- d. Place the test Hood from the regulator over the CO sensor.
- e. Push Next 3 times to get to the CAL menu then push Enter. It will display “tSC”. Push Next to go to “Spn” and push Enter. The display will flash back and forth between GAS and 200.
- f. Start applying gas to the CO sensor.  
**Note:** The sensor will look for the gas for 90 seconds. If no gas is applied or detected in that time, the display will return to CAL.
- g. When the sensor detects the gas, the display will flash back and forth between the CO concentration and SPn, then the calibration will progress, and the display will show the gas level for a maximum of 165 seconds.
- h. When the calibration is successful, the display will flash back and forth between CO concentration and PAS, then the display will show the calibration gas level and the calibration is done.
- i. If the calibration fails, the display will flash back and forth between the CO concentration and “Fail”. If this occurs, check the pressure gauge on the regulator. If the pressure is less than 25 psi the flow of gas may not be adequate to properly calibrate the unit. If there is proper pressure in the cylinder repeat steps 4 through 6. If the unit fails to calibrate twice contact Technical Support: 1-844-325-3050.
- j. Once the calibration has passed, remove gas and disassemble the cylinder and regulator.
- k. Re-assemble the CM-xx (make sure the LED is aligned with the front case hole). You are done.
- l. See Calibration Flowchart on the inside of the housing.



## 8 Appendix A – Table of Images

Figure 3-1 6-Series 4-20 mA Output diagram .....	8
Figure 3-2 6-Series Rear View .....	9
Figure 3-3 6-Series Alarm Control Panel diagram .....	9
Figure 3-4 6-Series DVP-120 Control Panel diagram .....	10
Figure 3-5 6-Series Multiple Device diagram .....	11
Figure 3-6 6-Series Stand Alone Diagram .....	11
Figure 3-7 6-Series Alternate Alarm Panel .....	11
Figure 3-8 6-Series Horn & Strobe Combo Wiring .....	12
Figure 3-9 12-Series 4-20 mA Output Diagram .....	13
Figure 3-10 12-Series Rear View .....	13
Figure 3-11 12-Series Stand Alone Diagram .....	14
Figure 3-12 12-Series Multiple Device Diagram .....	15
Figure 3-13 12-Series Alarm Control Panel Diagram .....	15
Figure 3-14 12-Series DVP-120 Control Panel Diagram .....	15
Figure 3-15 12-Series Alternate Alarm Panel .....	16
Figure 3-16 12-Series Horn & Strobe Combo Wiring .....	16
Figure 4-1 Board View .....	20
Table 5-1 Hexadecimal Display .....	24
Figure 7-1 Calibration Kit Connection .....	28



## 9 Appendix B – Menu Structure

### 9.1 Main Menu

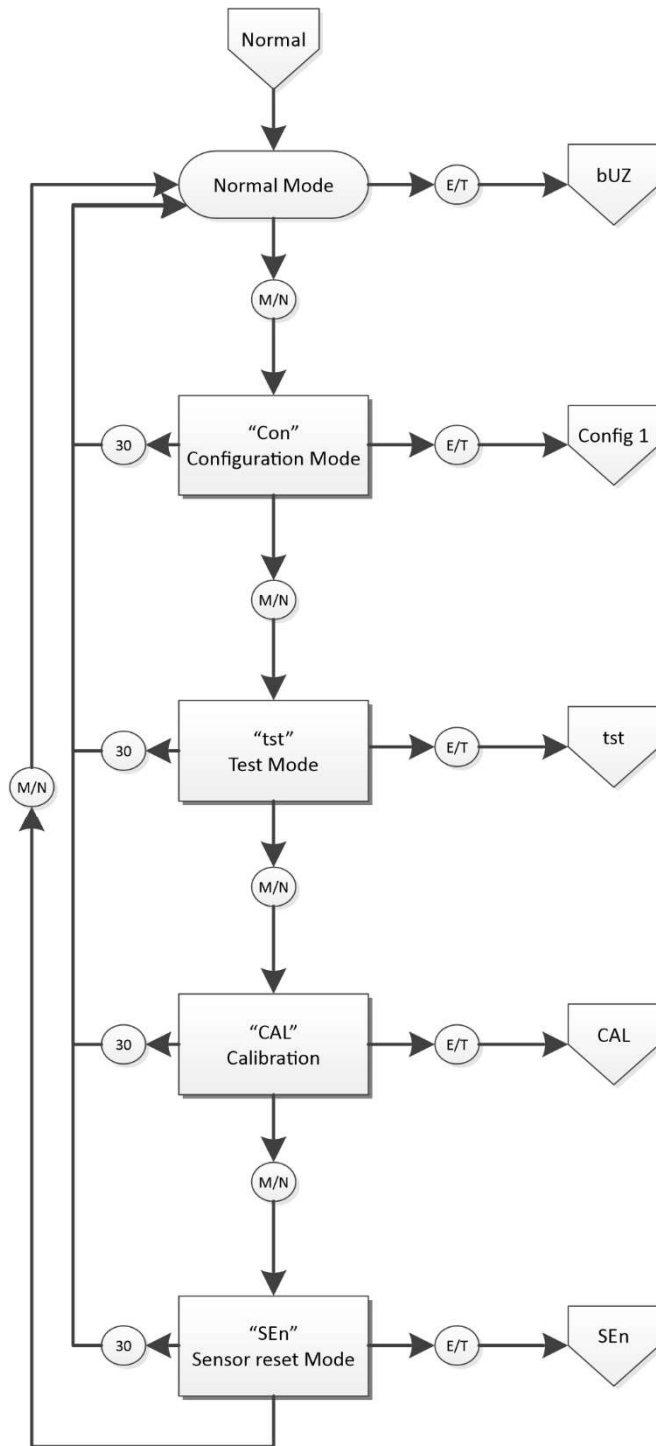



## 9.2 Auto Test Menu "bUZ"

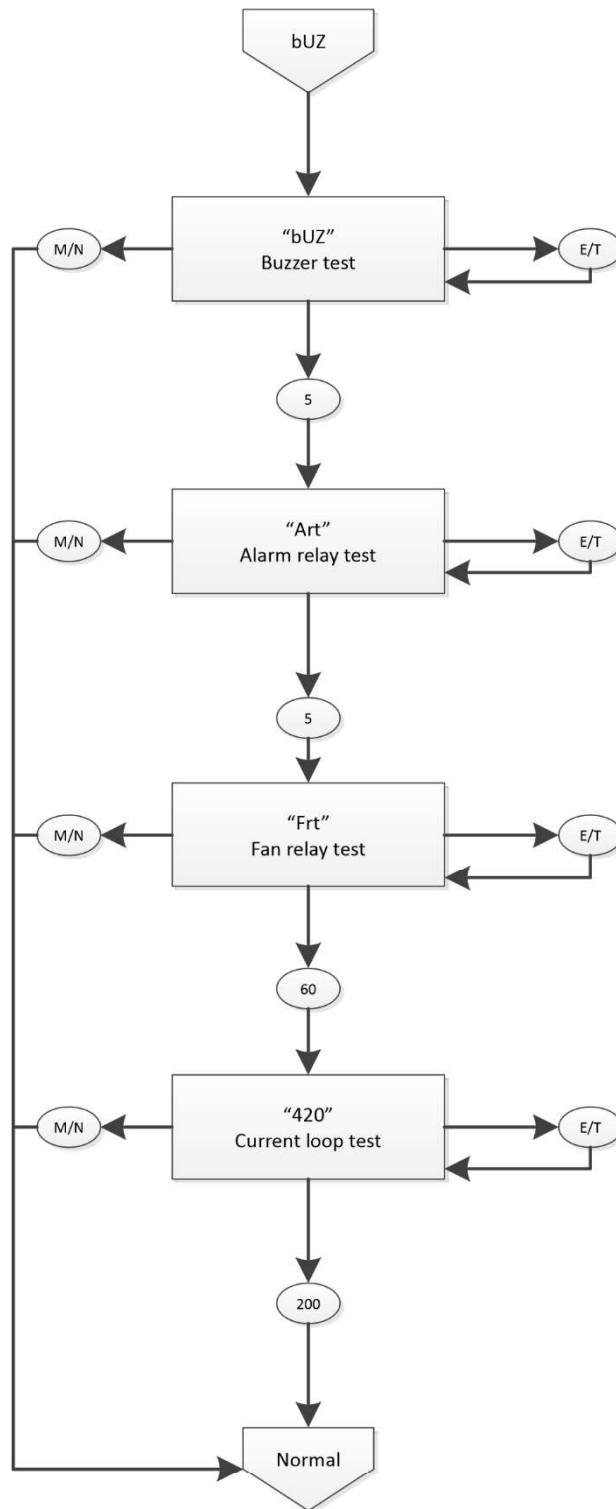

Configuration Menu "CON"

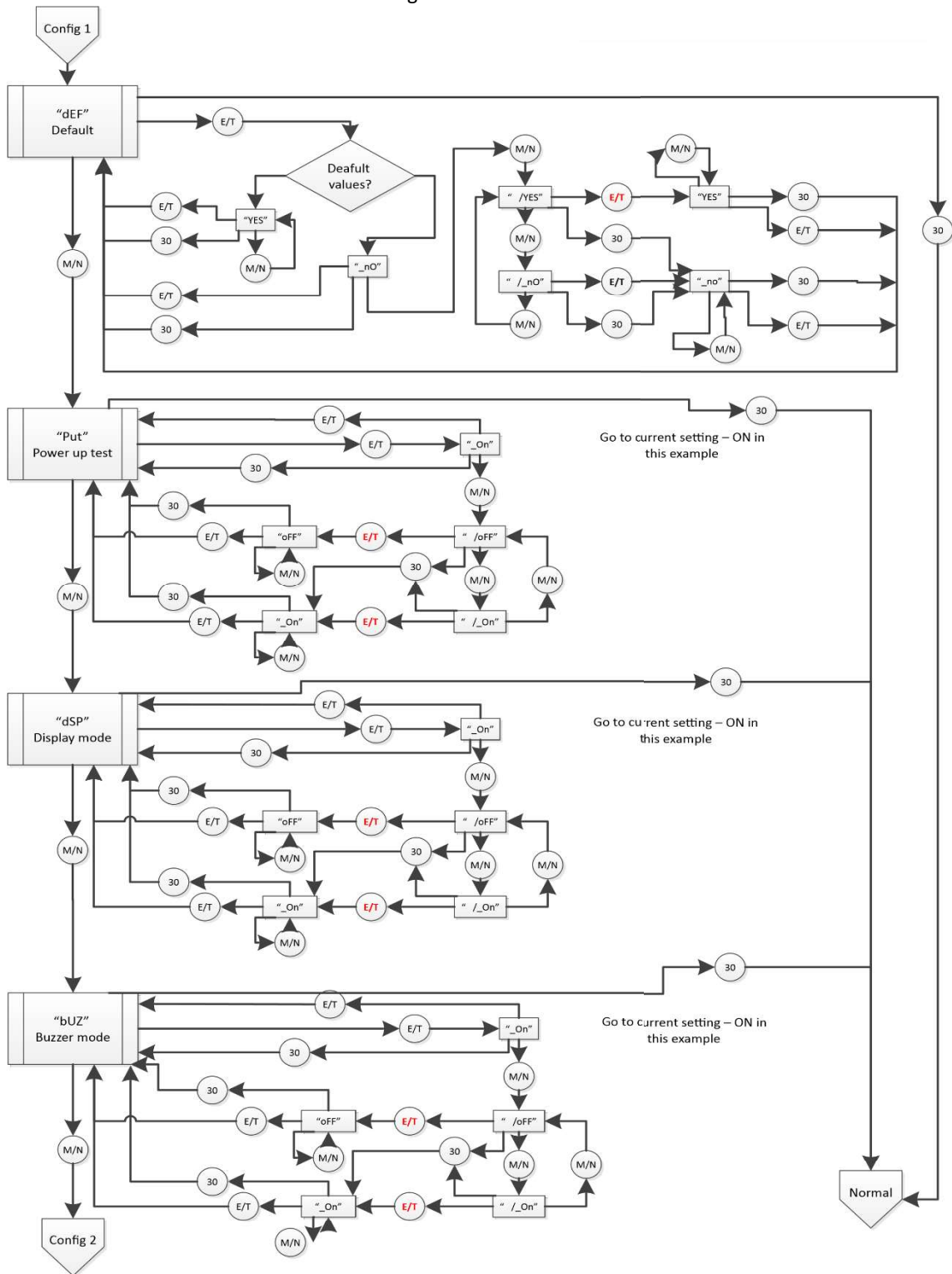

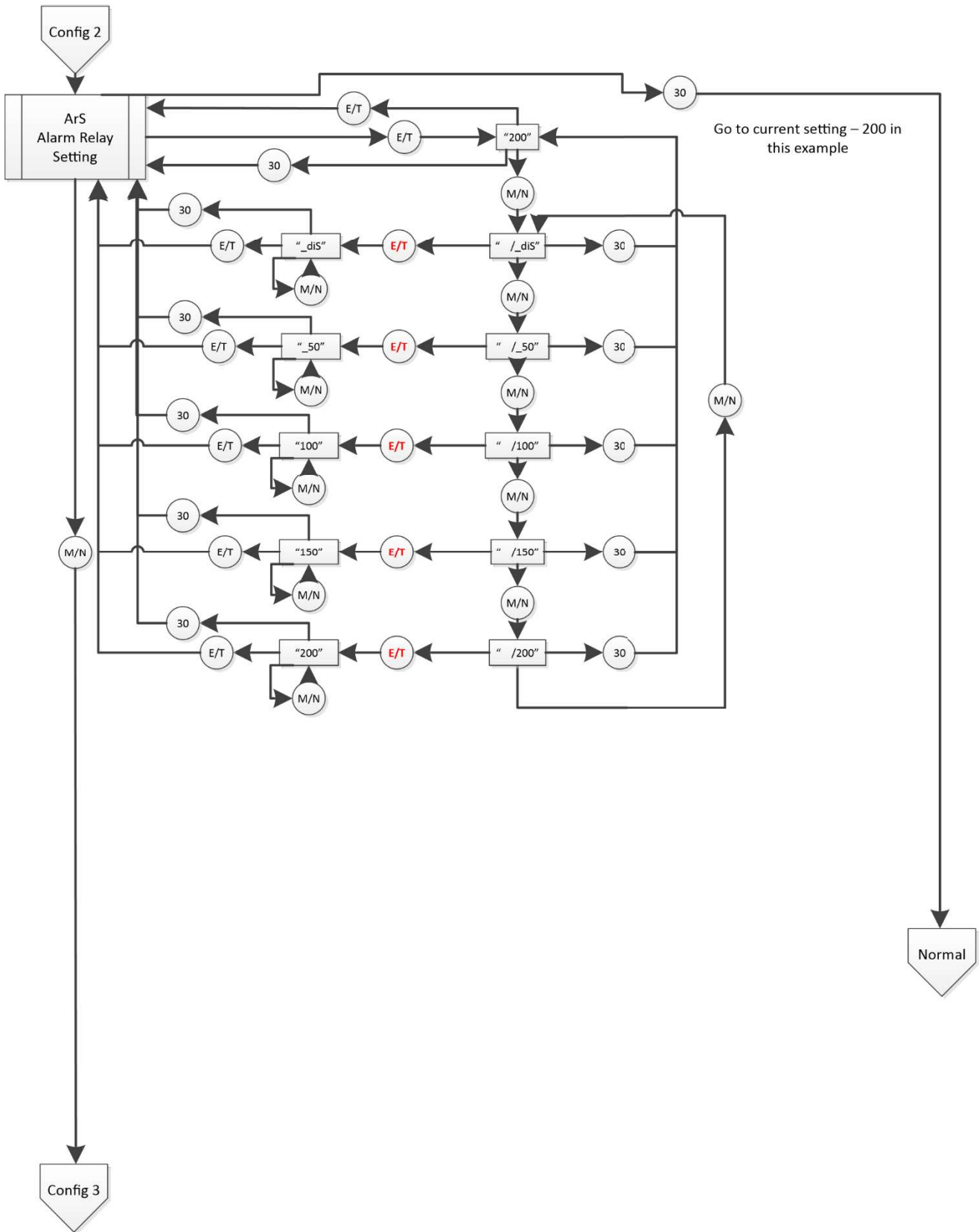

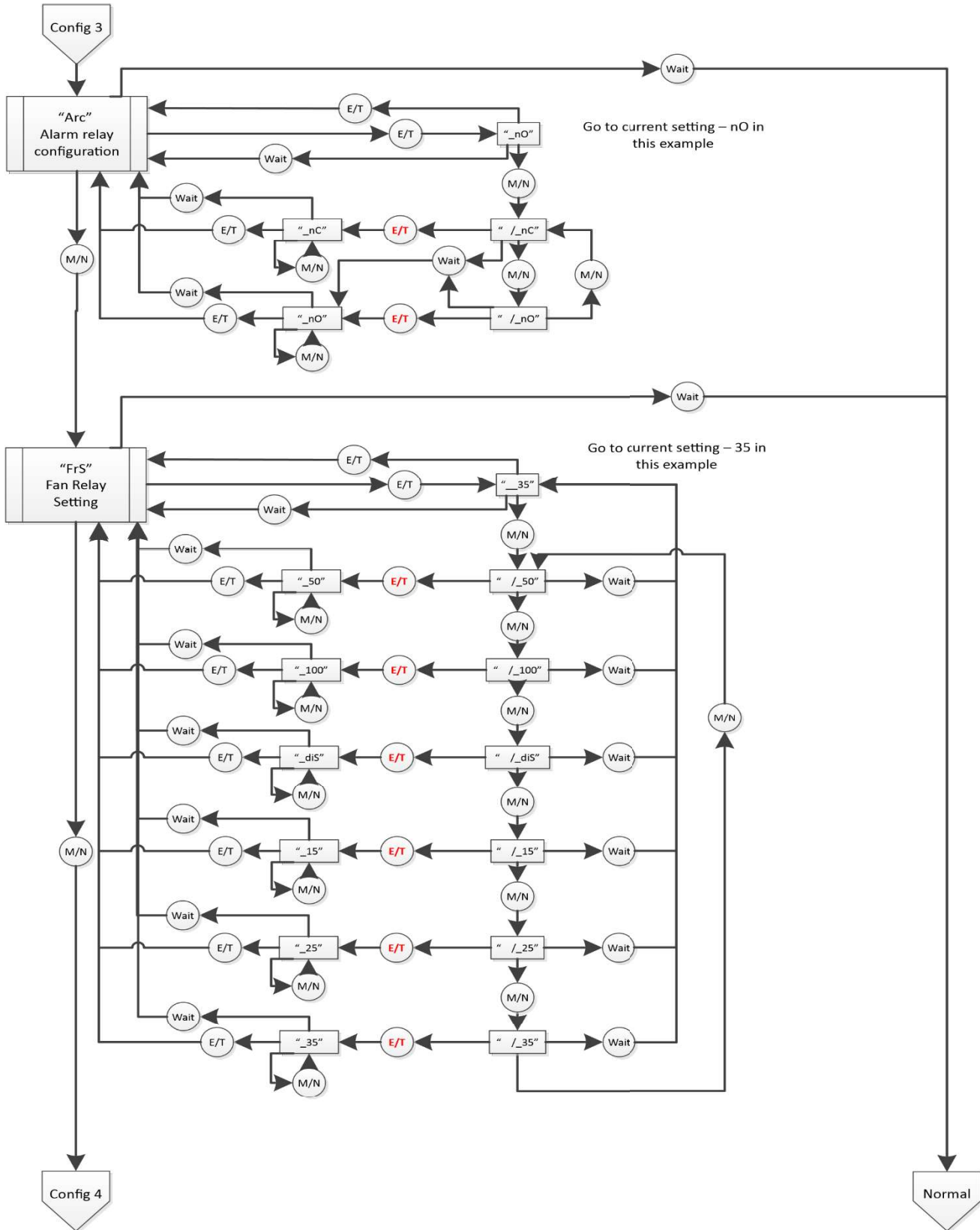

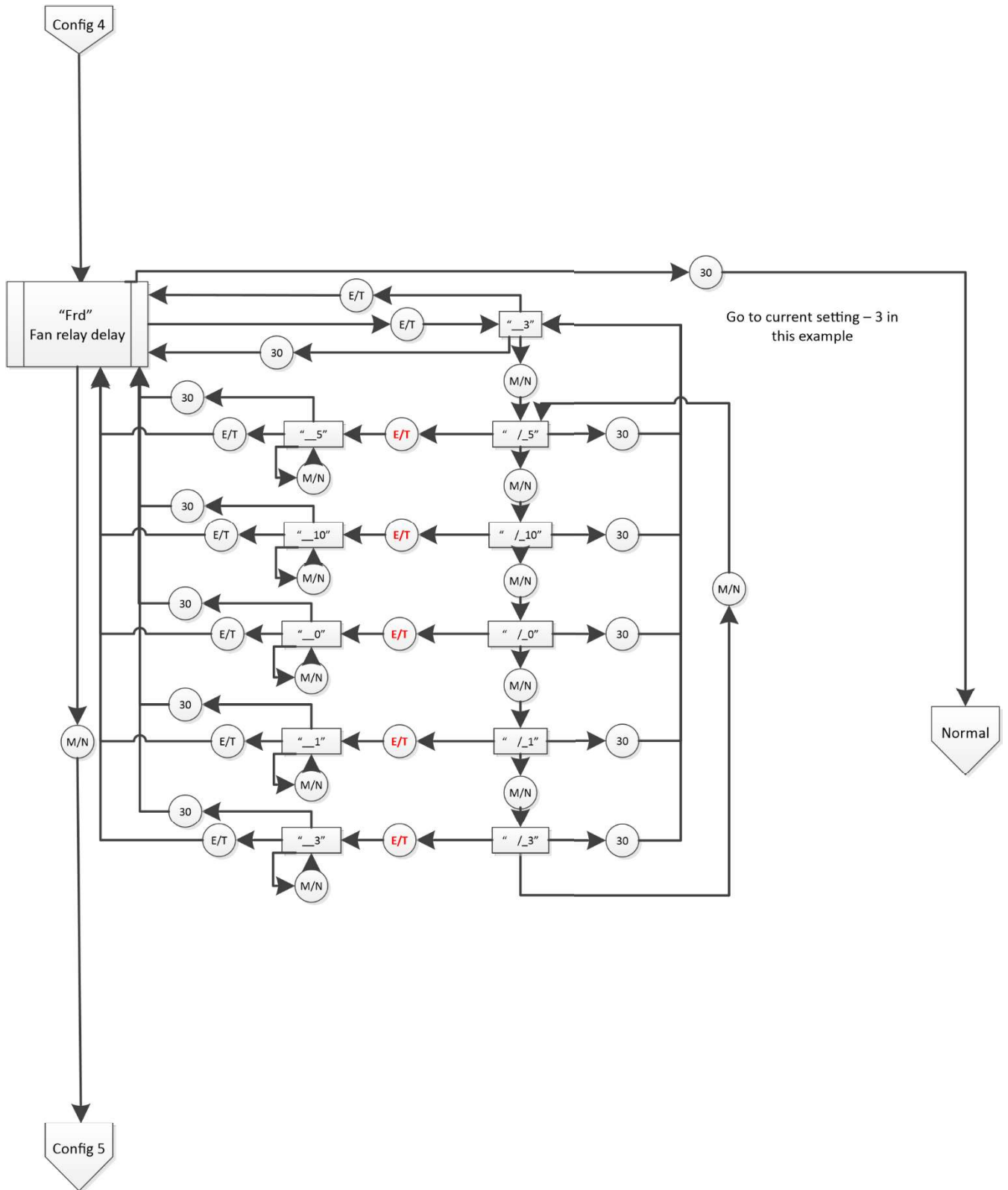

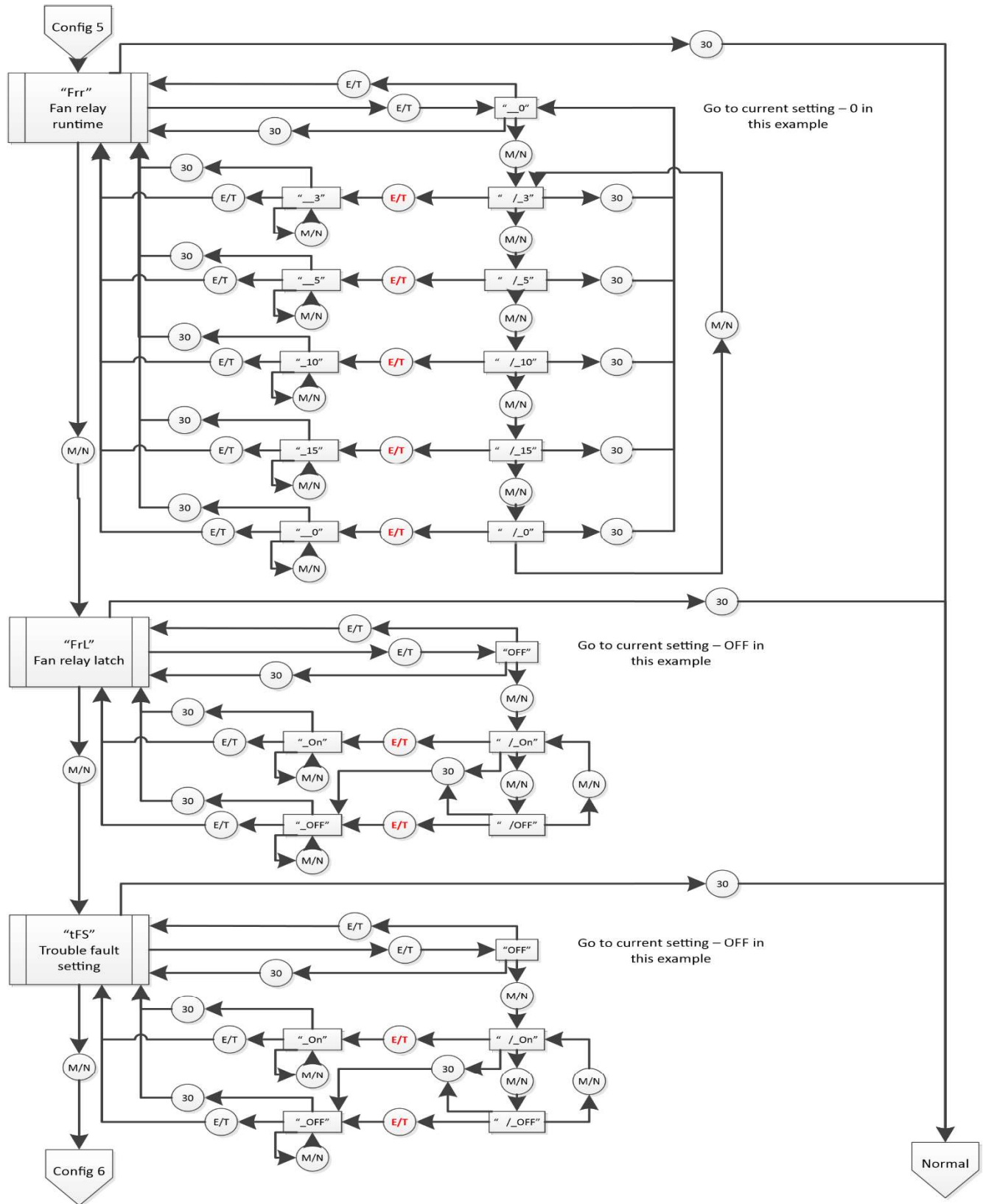

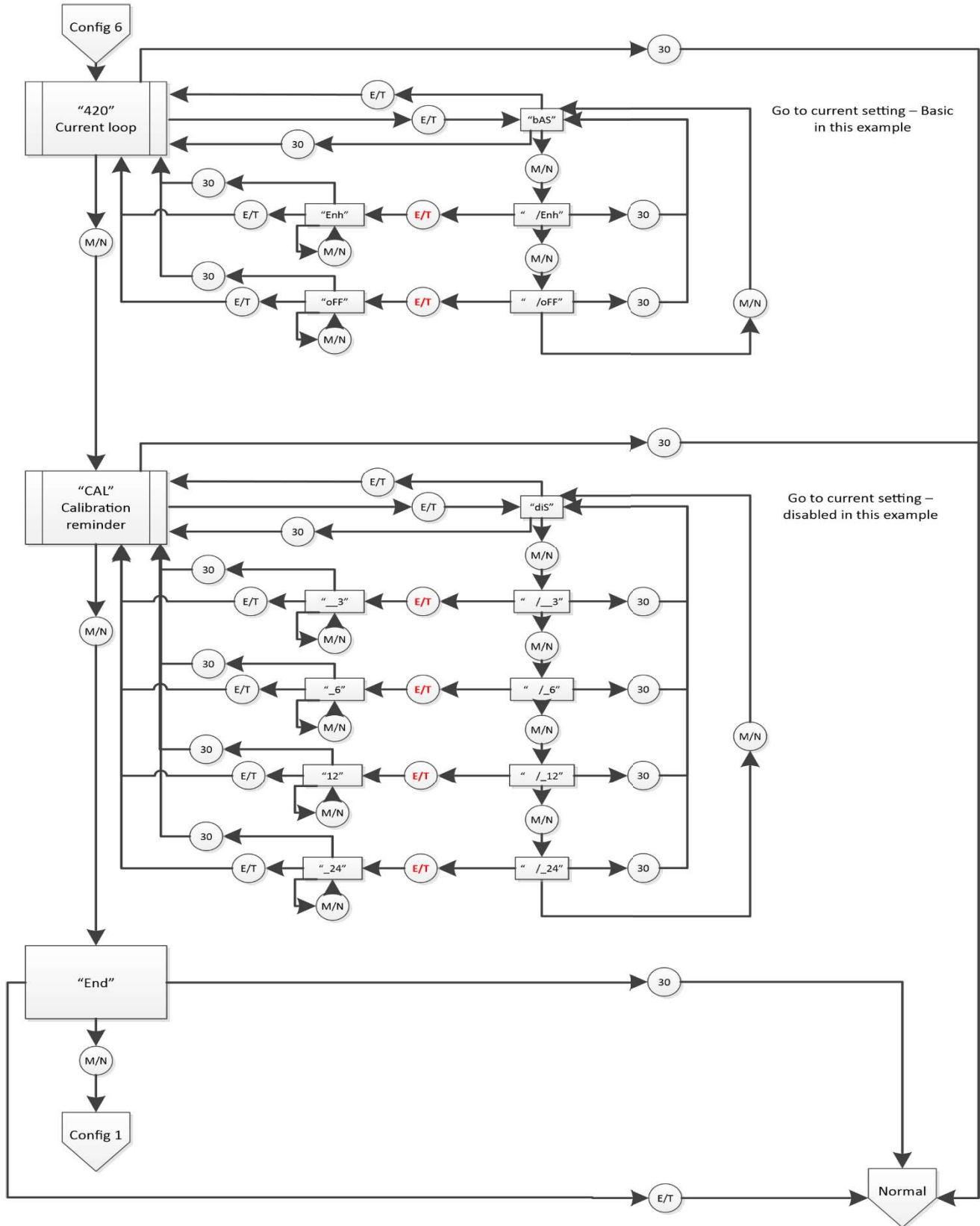

### 9.3 Select Test Menu "tst"

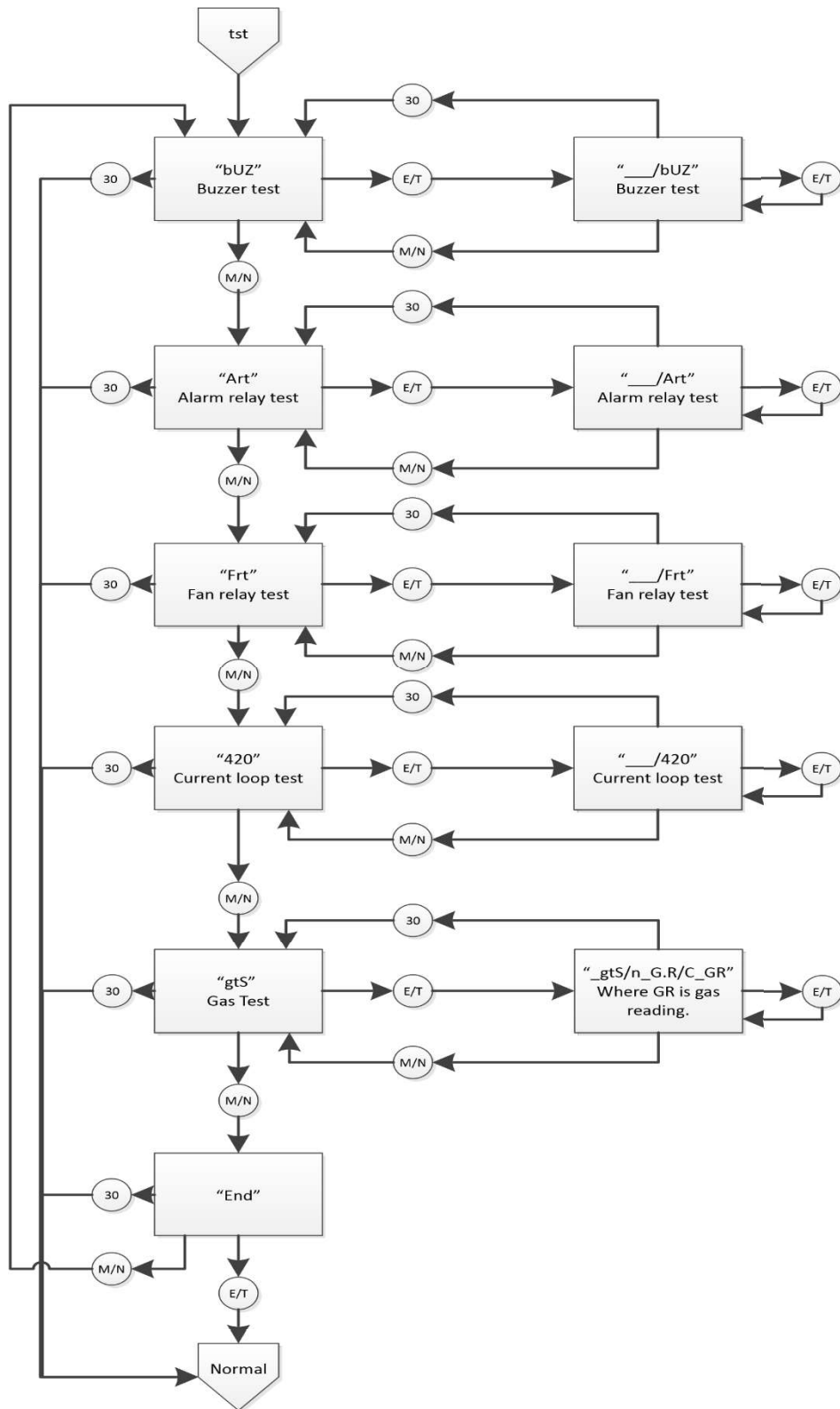



### 9.4 Calibration Menu "CAL"

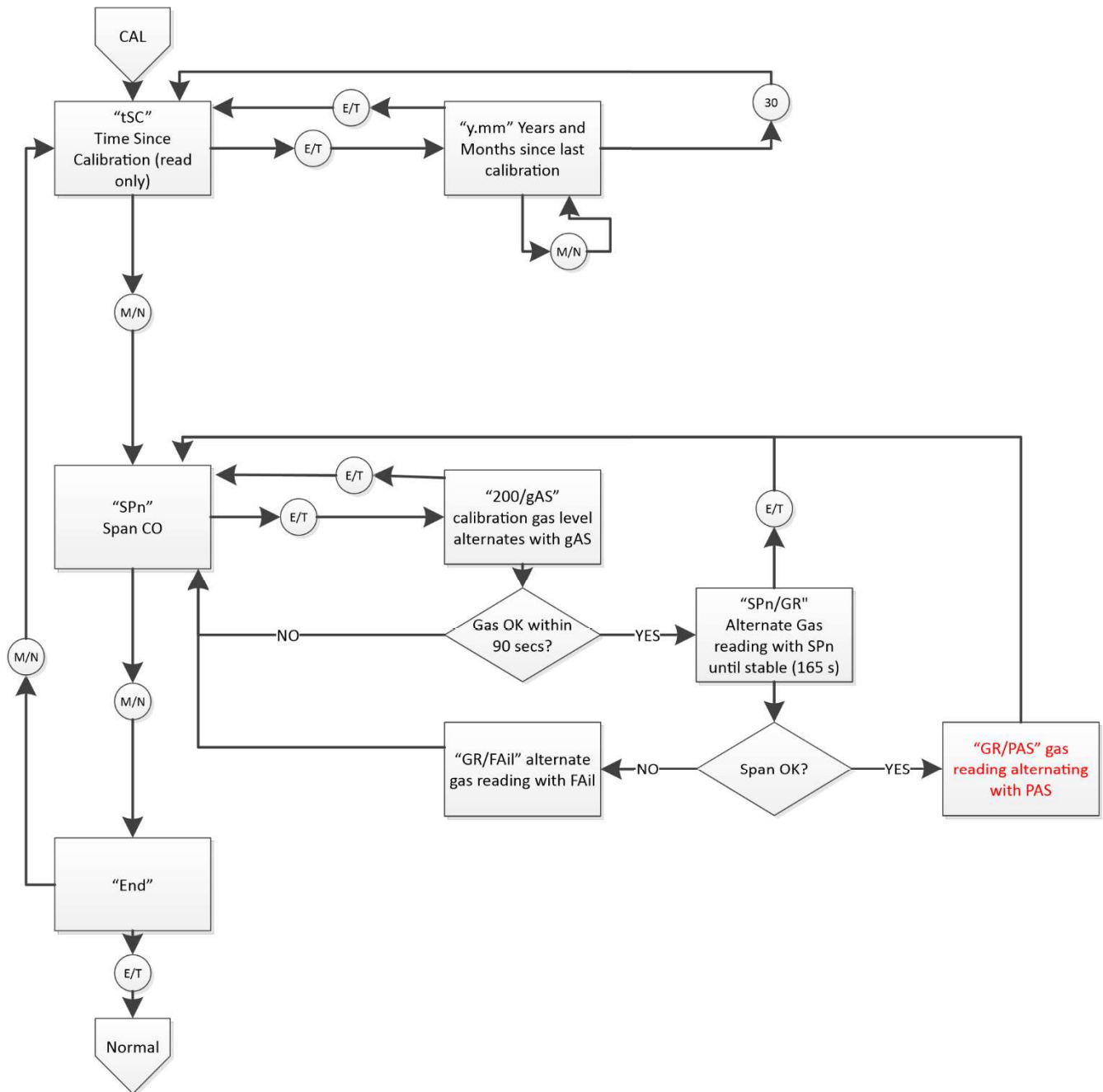

### 9.5 Sensor Reset Menu "SEn"

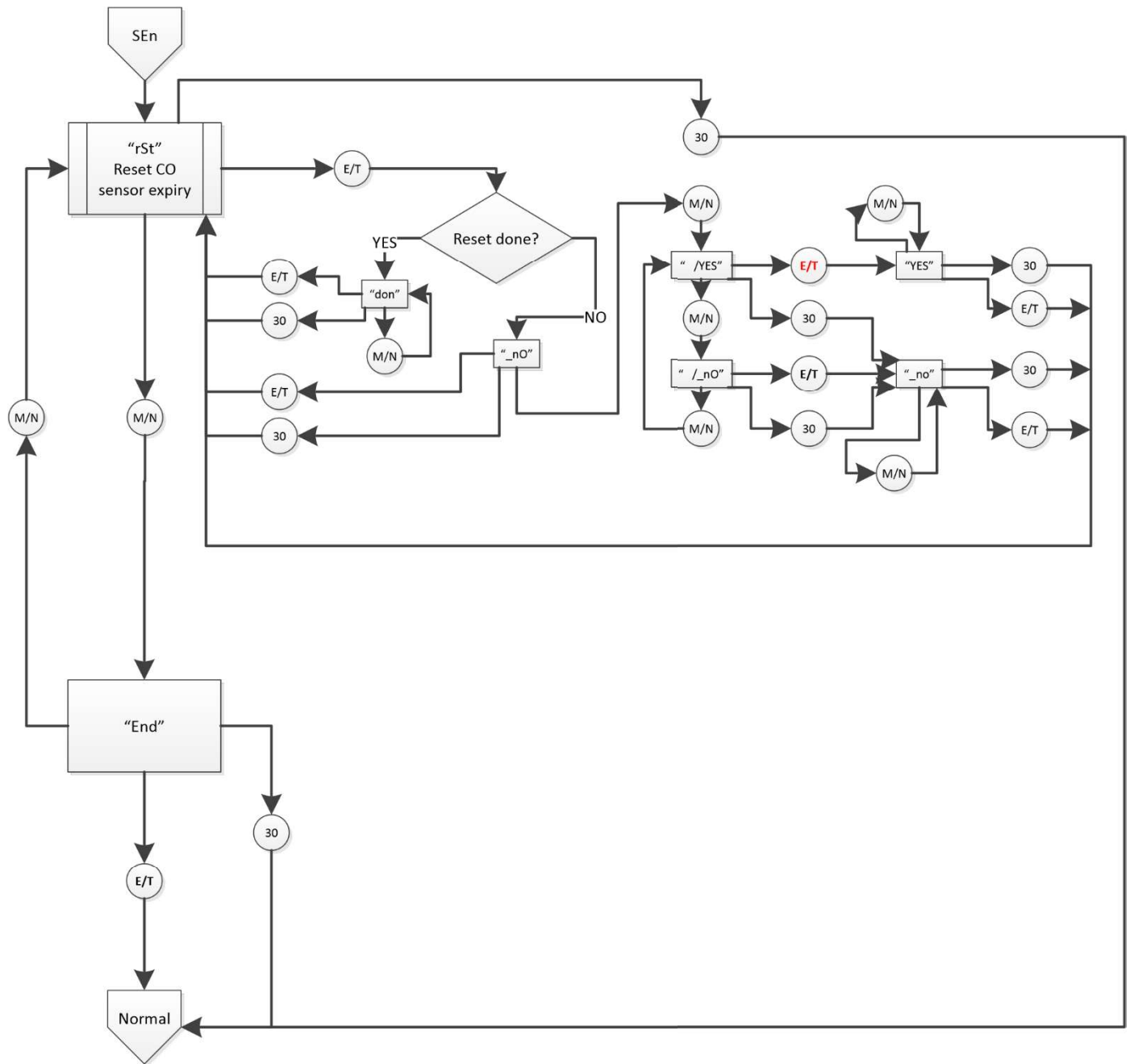

## 11 Macurco Gas Detection Product limited warranty

Macurco warrants the CM-6 gas detector will be free from defective materials and workmanship for a period of two (2) years from date of manufacture (indicated on the inside cover of the CM-6), provided it is maintained and used in accordance with Macurco instructions and/or recommendations. If any component becomes defective during the warranty period, it will be replaced or repaired free of charge, if the unit is returned in accordance with the instructions below. This warranty does not apply to units that have been altered or had repair attempted, or that have been subjected to abuse, accidental or otherwise. The above warranty is in lieu of all other express warranties, obligations, or liabilities. THE IMPLIED WARRANTIES OF MERCHANTABILITY AND FITNESS FOR PARTICULAR PURPOSE ARE LIMITED TO A PERIOD OF TWO (2) YEARS FROM THE PURCHASE DATE. Macurco shall not be liable for any incidental or consequential damages for breach of this or any other warranty, express or implied, arising out of or related to the use of said gas detector. Manufacturer or its agent's liability shall be limited to replacement or repair as set forth above. Buyer's sole and exclusive remedies are return of the goods and repayment of the price, or repair and replacement of non-conforming goods or parts.

### Macurco Inc.

1504 W 51st St  
Sioux Falls, SD 57105

#### Technical Support Contact Information

**Phone:** 1-844-325-3050  
**Fax:** 1-605-951-9616  
**Email:** support@macurco.com  
**Website:** www.macurco.com/support/

#### General Contact Information

**Phone :** 1-877-367-7891  
**Fax :** 1-605-951-9616  
**Email :** info@macurco.com  
**Website:** www.macurco.com

Rev – 1.2.1  
Issue Date: 01.18.2023  
Document No: 34-2900-0511-6  
© Macurco 2023. All rights reserved.

