



tPrime™ Series 280T-S

ULTRASONIC HEAT METER

Applications

- Residential submetering
- Commercial buildings
- District heating / cooling
- HVAC
- Green energy management
- AMR and Billing



Features

- Wear-free. Maintenance-free
- Unique sensor design for robust performance in both clear water and dirty water
- Multipath technology for increased accuracy
- Excellent long-term stability. Accuracy does not degrade over time
- Exceed OIML R75 class 2. Billing grade
- IP68 water-proof rated for the sensor, IP67 for the integrator
- Powered by both battery and M-Bus for extended lifespan
- For both heating and cooling circuits
- Free positioning
- Ready for AMR with M-Bus / Modbus / BACnet interface
- Low cost of ownership
- Data Logger with 24 monthly totals
- SpireCapture AMR/AMI and Billing solutions

DS-280T-S_2101_Rev6US



Spire Metering Technology LLC, 249 Cedar Hill Street, Marlborough, MA 01752, USA

Tel +1 978 263-7100 / 888 738-0188 (toll-free) Fax +1 978 418-9170 sales@spiremt.com www.SpireMT.com



tPrime™ Series 280T-S

ULTRASONIC HEAT METER



The tPrime™ series ultrasonic heat meter, often called a BTU meter, offers the most advanced heating/cooling energy measurement available, by using state-of-the-art ultrasonic flow measurement technology. With no moving parts, the meter has no wear and requires no maintenance.

With its maximum 200°F / 95°C water operating temperature and nominal pressure of 1.6MPa, the technical specifications of the tPrime™ series meet the standards for residential and commercial utility metering. The wide dynamic range allows for a load of up to double the rating, thereby ensuring high operational security. The large display can be set to show the heat consumption, temperature, flow total, working time, flow rate and more. The meter also has a remote readout which can be configured as M-Bus, RS485/Modbus, BACnet and more.

This new BTU meter system is powered by a lithium battery. However, whenever an MBus concentrator is connected, it will automatically draw power from the concentrator through the MBus connection. This unique feature extends the battery life of the meter.

The BTU calculation is according to the EN1434 heat meter standard. The formulas have been carefully implemented in the microprocessor to reduce the computational error to a minimum.

Spire Metering's ultrasonic BTU meter stands out among the competition due to its unique sensor design and multipath technology. It is able to work reliably even when the water is dirty. Both commercial and residential installations can profit from the advantages of the wear-free heating/cooling energy measurement, namely; precision, operational security and long service life.





Operating Principle

The tPrime™ series BTU meter consists of an ultrasonic flow sensor, a pair of PT1000 temperature sensors and an integrator. The microprocessor-based integrator controls the ultrasonic sensor to transmit and receive ultrasound in an orderly fashion so as to conduct precise flow measurement. It also has electronics dedicated to the PT1000 sensor to measure the temperature in the supply pipe as well as the return pipe. The integrator calculates the heat energy based on the flowrate and the temperature difference between the supply and the return.

The figure below illustrates how the thread type ultrasonic flow sensor works. Two ultrasonic transducers (A and B) are mounted on the flowcell body of the flow sensor; one is on the upstream and the other on the downstream. Two reflectors are used to direct the sound from one sensor to another. The integrator operates by alternately transmitting

and receiving a burst of sound energy between the two transducers and measuring the transit-time it takes for sound to travel between the two transducers. The difference in the transit-time measured corresponds directly to the velocity of the liquid in the pipe.

Unique Multi-path Technology

For large size meters, it is not easy to install the flow sensor perfectly in line with the pipe line. A small misalignment could cause flow profile distortion inside the flow sensor, causing significant measurement errors. Spire Metering developed a unique multi-path technology to solve this problem. Two pairs of ultrasonic transducers are mounted on the flow sensor body to interrogate the flow from two different paths (refer to figure below). A flow calculation algorithm based on fluid dynamics theory is then used to derive an average flow reading with improved accuracy.

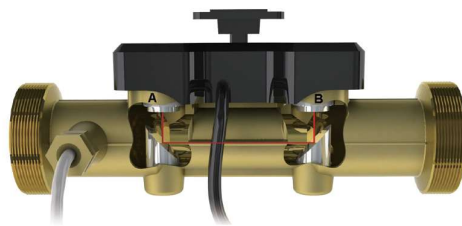

Thread Type (Small)

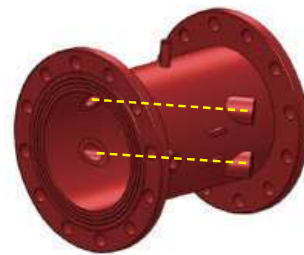

Flange Type (Large)



tPrime™ Series 280T-S

ULTRASONIC HEAT METER

Automatic Meter Reading

The tPrime™ series BTU meter offers a variety of interface options, such as M-Bus, RS485 with Modbus or BACnet. This flexibility allows for easy integration into an AMR/AMI system.

Spire Metering also offers a complete range of AMR/AMI solutions, as well as an integrated billing system. Its SpireCapture system is a cutting edge fixed automatic meter reading system which integrates both wired and wireless AMR/AMI technologies. It provides a unified platform for meter reading and data management through M-Bus and GPRS networks, as well as TCP/IP networks. In addition, it works seamlessly with Spire Metering's billing software to make data exchange easy, fast and reliable.

SpireCapture is an advanced, highly robust meter reading solution that delivers comprehensive usage information as well as timely, high-resolution meter reading. This data enables gas, water, heat and electric utilities to eliminate on-site visits and estimated reads, reduce theft loss, implement time-of-use billing, and profit from all of the financial and operational benefits of fixed-network AMI/AMR.

A typical M-Bus based AMR system is illustrated in the below figure. It is consisted of a number of M-Bus utility meters, several M-Bus concentrators, a GPRS wireless modem for each concentrator and a data center. The concentrator communicates with the data center through a GPRS network. The data center first issues a meter reading command and sends it to the wireless network. The modem receives the command and forwards it to the M-Bus concentrator. Then, the concentrator either replies to the command with requested data or passes the command to its sub meters transparently.

For information on AMR/AMI components, such as concentrators, repeaters, protocol convertors, data collection devices and etc., **please contact solutions@spiremt.com**

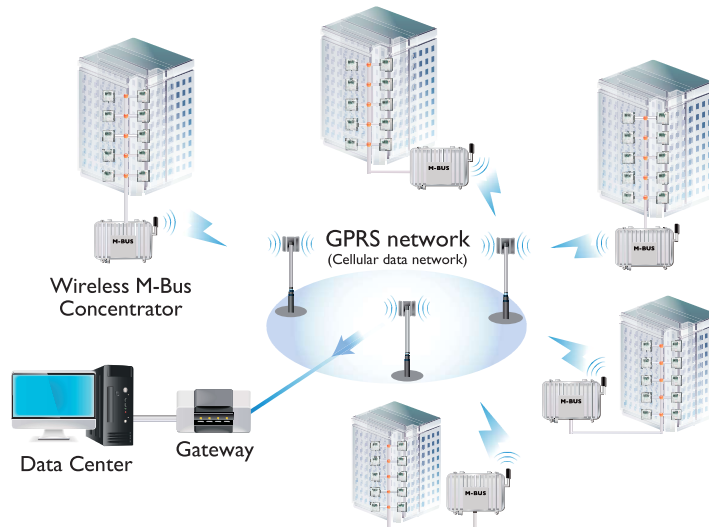



tPrime™ Series 280T-S

ULTRASONIC HEAT METER

Specifications

Diameter	Flowrate (GPM)			Dimension (IN)			Weight* (LBS)	Process Connection	
	Qmin	Qn	Qmax	L	W	H		Sensor	Tailpiece
¾	0.22	11	22	5.12	4.72	4.13	2.64	BPS G1B	¾ NPT
1	0.308	15.4	30.8	6.3	4.72	4.33	3.52	BPS G1¼B	1 NPT
1 ½	0.88	44	88	7.87	4.72	4.92	6.16	BPS G2B	1 ½ NPT
2	2.64	66	132	7.87	6.49	7.75	23.76	CL 150 ANSI B16.5 Flange**	
3	7.04	176	352	8.86	7.87	9.94	37.18	CL 150 ANSI B16.5 Flange**	
4	10.56	264	528	9.84	8.66	9.72	43.78	CL 150 ANSI B16.5 Flange**	
6	26.4	660	1320	11.81	11.22	10.90	63.8	CL 150 ANSI B16.5 Flange**	
8	44	1100	2200	13.78	13.38	12.87	107.58	CL 150 ANSI B16.5 Flange**	
10	70.4	1760	3520	17.72	15.94	16.22	206.58	CL 150 ANSI B16.5 Flange**	

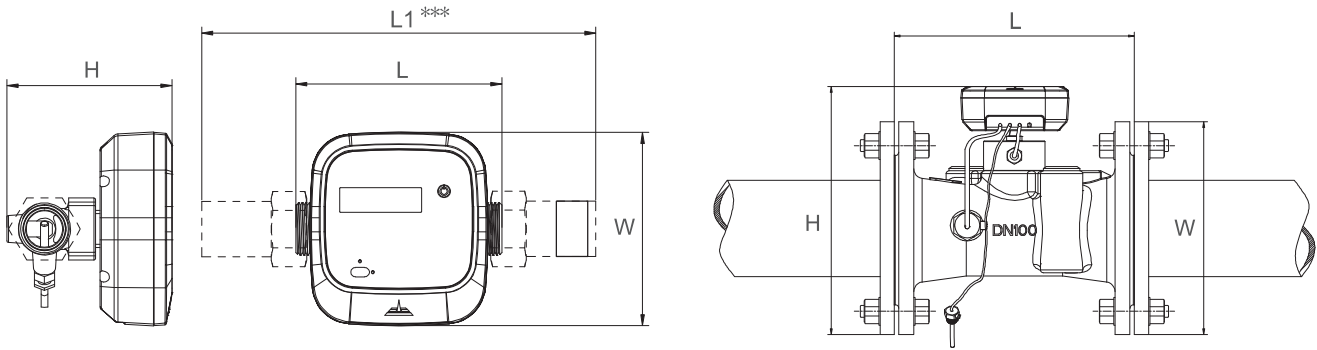

Notes:

*Weight may differ depending on accessories.

**The flange thickness may be slightly thinner than ANSI standard.

*** L1 equals L plus 4.02" for ¾" size, 4.76" for 1" size and 5.04" for 1 ½" size.



tPrime™ Series 280T-S

ULTRASONIC HEAT METER

Electrical Data

Power Supply:	Battery, 3.6V, Lithium. Alternatively, the meter can be powered by MBus with current draw less than 3mA
Replacement Interval:	5 years at $t_{BAT} < 30^{\circ}C$ ($86^{\circ}F$)
Power Consumption:	<0.2W
Standby Current:	<10uA
Backup Power Supply:	Internal SuperCap
Communication Interface:	M-Bus (default). Optional: RS485 with MODBUS or BACnet/MSTP
CE approval:	EN61326-1:2006

Accuracy / MPE (Maximum Permissible Error)

MPE according to OIML R75 / EN1434, the whole system error is the combination of the following:

Calculator (Integrator):	$E_c = \pm (0.5 + \Delta\Theta_{min} / \Delta\Theta)$
Temperature Sensor:	$E_t = \pm (0.5 + 3\Delta\Theta_{min} / \Delta\Theta)$
Flow Sensor:	$E_f = \pm (2 + 0.02 qp / q)$

Here $\Delta\Theta$ is the temperature difference between the flow (supply) and return of the heat exchange circuit. q is the flow rate and qp is the nominal flow rate.

NOTE: The actual error of 280T-S meters is much smaller than the above MPE.

Calculator (Integrator)

Display:	LCD, 8 digits
Resolution:	999.99999 - 999999.99 - 99999999
Energy Unit:	KBTU or KWH
Communication Protocol:	M-Bus (default). Optional: MODBUS or BACnet



tPrime™ Series 280T-S

ULTRASONIC HEAT METER

Fluid Temperature Measurement

Sensor Type: PT1000, 2-wire.
Sensor Measurement Range: 0~150°C (32~302°F)
Difference Range: ΔΘ: 3K-70K
Permissible Operating Θ: 2~60°C (35~140°F) for long term and up to 95°C (203°F) Temperature: for short term

Mechanical Data

Metrological Class: 2 (according to OIML R75 / EN1434)
Environmental Class: B
Electromagnetic Class: E1
Environmental Temp: 0-55°C (32-131°F)
Enclosure Protection: IP68 water-proof rated for the sensor; IP67 for the integrator
Integrator Detachable: Yes
Pressure: PN16
Flow Sensor Cable: 1.2m (5m length available)
Temperature Sensor Cable: 1.2m (5m length available)

Pressure Loss

The pressure loss of a flow sensor is proportional to the square on the flow: $\Delta p = k \times q^2$
 Here Δp is pressure loss, q is volume flow rate and k is the coefficient.
 All meters have Δp less than 0.25bar at q_p .



tPrime™ Series 280T-S

ULTRASONIC HEAT METER

Order Specifications

280T - SIN - - - - -

Size*	ID
¾"	0075
1"	0100
1 ½"	0150
2"	0200
3"	0300
4"	0400
6"	0600
8"	0800
10"	1000

Output Interface	ID
Serial TTL (opto-isolated)	0
M-Bus (Default)	1
RS485 / Modbus	8
Pulse (OCT)	A
RS485 (for BACnet adapter)	B

ID	Unit System
E	US Gal / English (Default)
M	Metric

ID	Pressure
1	1.6MPa (232 psig)

ID	Temperature
A	Standard Temperature

ID	Pipe Joint
B	NPT (Meter body will have BSP threading with NPT Extension pieces)
D	ANSI Flange (Upon request for DN50 and above)

***Note:** Larger sizes available upon request

Optional Adapter (The Output Interface for the above main unit must be Serial TTL or RS485 for BACnet)

Output Interface Module	Model No.
BACnet / MSTP adapter	280AP-MSTP
RS485 / Modbus	280AP-MOD
4-20mA+RS485 / Modbus	280AP-MODAO

Example

280T-SIN0400-8-D-A-1-E

stands for the 280T-S tPrime™ series BTU meter for 4" pipe with RS485 / Modbus interface, ANSI flange pipe joint, standard pressure and temperature rating. English unit system.



tPrime™ Series 280T-S

ULTRASONIC HEAT METER

Small size BTU meter (3/4" 1" 1 1/2")



- Integrator
- Interface Cable
- Flow Sensor Cable
- Temperature Sensor Cable

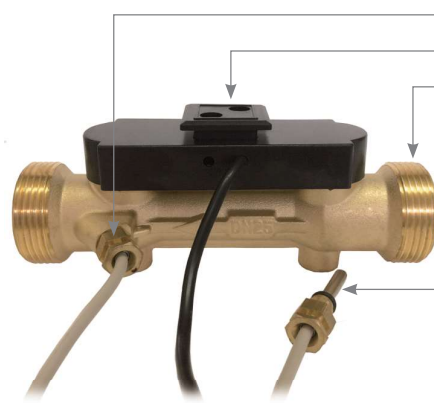

- Temperature Sensor 1 (already installed)
- Integrator Holder
- Flow Sensor
- Temperature Sensor 2

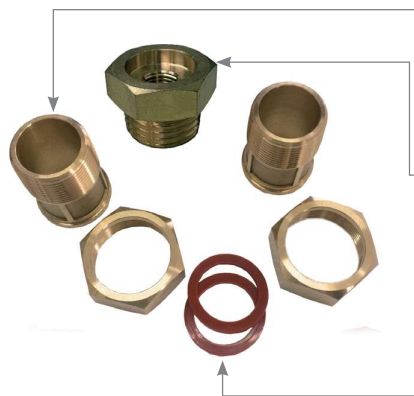

- Tail Piece / Extension Piece
- Thread Adapter (for return temp sensor)
- Gasket



tPrime™ Series 280T-S ULTRASONIC HEAT METER

Large Size BTU Meter (2")





tPrime™ Series 280T-S

ULTRASONIC HEAT METER

Large Size BTU Meter (3"~10")

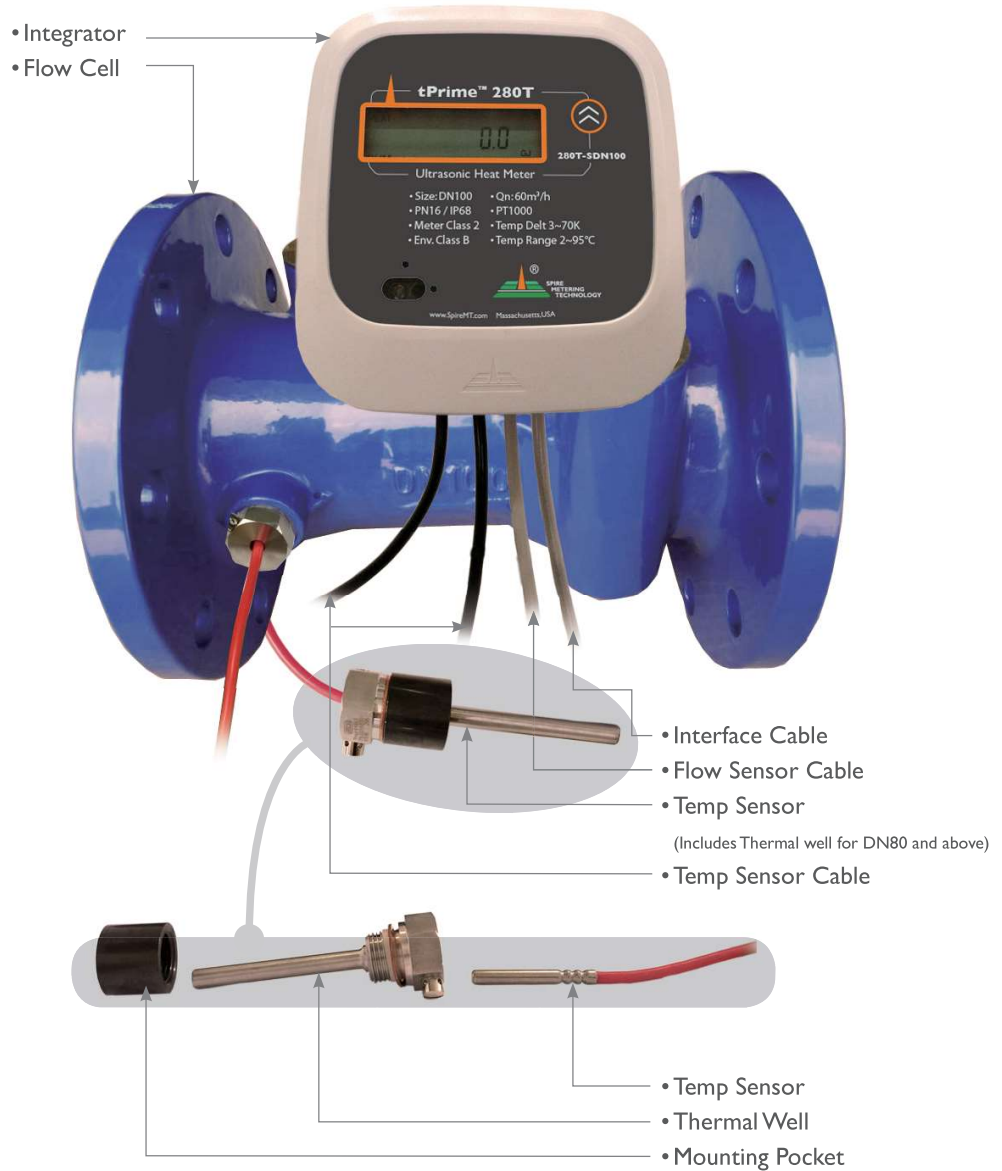



tPrime™ Series 280T-S

ULTRASONIC HEAT METER

Memo

About Spire Metering Technology

Spire Metering is a global leader in flow and energy management solutions. Through continuous innovation, we transform complex ultrasonic technology into affordable, reliable solutions for accurate flow and energy measurement. Spire Metering offers water, heat, and electricity meters as well as AMR/AMI solutions. To find out how we can help today, please tell us about your application.